

DXP38

HF RADIO DSP MODEM

OPERATOR'S MANUAL



**HAL COMMUNICATIONS
P.O. BOX 365
URBANA, IL 61803-0365**

QUALITY COMMUNICATIONS EQUIPMENT



DXP38

HF RADIO DSP MODEM

OPERATOR'S

MANUAL

Copyright 1998 © by HAL Communications Corp., Urbana, Illinois. Printed in the United States of America. Contents of this publication may not be reproduced in any form without the written permission of the copyright owner.

870-13800
October 14, 1999 Printing



Table Of Contents

Chapter 1.	Introduction	
1.1	The DXP38 Manual.....	1-1
1.2	DXP38 Software.....	1-1
1.2.1	Minimum Requirements	1-2
1.2.2	Software and Documentation Up-Date	1-2
Chapter 2	Installation and Set-Up	
2.1	Unpacking and Inspection.....	2-1
2.2	DXP38 Rear Panel Connections.....	2-2
2.2.1	Audio Input.....	2-2
2.2.2	Audio Output	2-4
2.2.3	PTT Output.....	2-4
2.2.4	FSK Output	2-5
2.2.5	SEL-CAL Output	2-6
2.2.6	RS-232 Connections	2-6
2.2.7	Ground Connection.....	2-7
2.2.8	DC Power Connection	2-7
2.3	Initial Transmitter and Receiver Adjustment	2-7
2.4	Front Panel Status and Tuning Indicators	2-9
2.4.1	Status Indicators	2-9
2.4.2	Tuning Indicator - M/S Mode.....	2-9
2.4.3	Tuning Indicator - Δf Mode.....	2-9
2.4.4	Print Squelch Indicator.....	2-11
2.5	Special Considerations When Operating CLOVER	2-11
2.5.1	Transmitter and Receiver Requirements	2-11
2.5.2	Receiver Tuning of CLOVER-II Signals	2-12
2.5.3	Transmit Modulation	2-12
2.5.4	Receiver AGC and Noise Limiter	2-12
2.5.5	Receiver Filters	2-12
2.5.6	Receiver Audio Level.....	2-13
2.5.7	Adaptive Control and Radios	2-13
Chapter 3	Operation Under Windows	
3.1	Installing DXPWin Software	3-1
3.1.1	The DXPWin Setup Window	3-2
3.1.2	Changing DXPWin Directory.....	3-2
3.1.3	Beginning Installation	3-2
3.2	Manual Conventions	3-3
3.3	Running DXPWin	3-5
3.4	MYCALL Setup	3-5
3.5	Main Screen	3-5
3.6	Menu Line	3-6
3.6.1	File Menu	3-6
3.6.2	Edit Menu	3-7
3.6.3	Code Menu.....	3-7
3.6.4	Configure Menu.....	3-7
3.6.5	Special Menu	3-8

3.7	Toolbar	3-8
3.8	Receive (RX) Buffer	3-9
3.9	Echo on Transmit (TX) Buffer	3-9
3.10	Transmit Buffer.....	3-9
3.11	Tuning Indicators.....	3-10
3.12	Status Bar	3-10
3.13	General Configuration.....	3-10
3.14	Operating RTTY.....	3-11
	3.14.1 RTTY Codes	3-11
	3.14.2 Starting RTTY	3-11
	3.14.3 RTTY Data Rates.....	3-12
	3.14.4 Control Options	3-12
	3.14.5 Configuration Options	3-13
	3.14.6 Special RTTY Transmit Keys.....	3-14
3.15	Operating CLOVER-II	3-14
	3.15.1 Tuning a CLOVER Signal	3-14
	3.15.2 RX/TX Status Table	3-15
	3.15.3 Adaptive ARQ Mode	3-15
	3.15.4 FEC Mode.....	3-16
	3.15.5 Listen Mode.....	3-17
	3.15.6 Test Mode.....	3-17
	3.15.7 CLOVER-II Configuration Menu Parameters	3-17
3.16	Operating AMTOR	3-18
	3.16.1 Control Options	3-18
	3.16.2 ARQ Mode	3-18
	3.16.3 FEC Mode.....	3-20
	3.16.4 Listen mode.....	3-20
3.17	Operating P-Mode.....	3-20
	3.17.1 Control Options	3-20
	3.17.2 ARQ Mode	3-21
	3.17.3 FEC Mode (UNPROTO)	3-22
	3.17.4 LISTEN Mode.....	3-22

Chapter 4 Operation Under DOS

4.1	Installing DXP38 Software	4-1
4.2	Manual Conventions	4-2
4.3	MYCALL Setup	4-3
4.4	Main Screen	4-3
	4.3.1 Tuning Indicators	4-4
	4.3.2 Receive (RX) Buffer	4-4
	4.3.3 Status Line	4-4
	4.3.4 Command Line.....	4-4
	4.3.5 Transmit (TX) Buffer	4-4
	4.3.6 Information Line	4-4
4.5	Configuration Screens	4-11
4.6	Hot-Keys	4-13
	4.6.1 Function Hot-Keys	4-13
	4.6.2 Alt-letter Hot-Keys.....	4-13
4.7	File Operations.....	4-16
	4.7.1 Load TX Buffer.....	4-16
	4.7.2 Save To Disk.....	4-16
	4.7.3 Stop Send / Save	4-17
	4.7.4 Send From Disk	4-18
	4.7.5 Directory.....	4-18
	4.7.6 Load DXP38.....	4-18

4.8	TX Buffer Editor.....	4-18
4.9	Operating RTTY.....	4-19
4.9.1	RTTY Codes.....	4-19
4.9.2	Starting RTTY.....	4-19
4.9.3	RTTY Data Rates.....	4-20
4.9.4	Control Menu Options.....	4-20
4.9.5	Configuration Menu Options.....	4-22
4.9.6	Print Squelch.....	4-23
4.9.7	Special RTTY Transmit Keys.....	4-23
4.10	Operating CLOVER-II.....	4-23
4.10.1	Tuning A CLOVER Signal.....	4-24
4.10.2	RX/TX Status Table.....	4-25
4.10.3	Adaptive ARQ Mode.....	4-26
4.10.4	FEC Mode.....	4-27
4.10.5	LISTEN Mode.....	4-28
4.10.6	Test Mode.....	4-28
4.10.7	CLOVER-II Configuration Menu Parameters.....	4-29
4.11	Operating AMTOR.....	4-29
4.11.1	ARQ Mode.....	4-29
4.11.2	FEC Mode.....	4-33
4.11.3	LISTEN Mode.....	4-33
4.12	Operating P-Mode.....	4-33
4.12.1	ARQ Mode.....	4-33
4.12.2	FEC Mode (UNPROTO).....	4-35
4.12.3	LISTEN Mode.....	4-36

Chapter 5 In Case Of Difficulty

5.1	User Adjustments and Alignment.....	5-1
5.2	DXP Hardware Problems.....	5-1
5.3	Software Problems.....	5-2
5.4	Operational Problems.....	5-2
5.5	User Service.....	5-3
5.6	User Information.....	5-3
5.7	Returning Equipment to Factory for Repair.....	5-4

Chapter 6 Specifications

Warranty

Tables

Table 2.1	DXP38 I/O Connections.....	2-2
Table 2.2	AF OUT Voltage Ranges	2-4
Table 2.3	DXP38 FSK Output Options	2-5
Table 2.4	FSK for Typical Amateur Transceivers	2-5
Table 2.5	RS-232 Data I/O Connections	2-7
Table 2.6	DXP38 Status Indicators.....	2-9
Table 2.7	CLOVER-II HF Radio Requirements	2-11
Table 3.1	RTTY Data Rates and Speeds	3-11
Table 3.2	RTTY and AMTOR Default Settings	3-12
Table 3.3	Baudot Code Differences.....	3-13
Table 3.4	Special RTTY Transmit Keys.....	3-14
Table 4.1	Function HOT-KEY Assignments.....	4-14
Table 4.2	Alt-letter HOT-KEY Assignments.....	4-15
Table 4.3	Transmit Buffer Edit Keys	4-19
Table 4.4	RTTY Data Rates and Speeds	4-20
Table 4.5	RTTY Control Options.....	4-20
Table 4.6	Baudot Code Differences.....	4-22
Table 4.7	Special RTTY Transmit Keys.....	4-23
Table 5.1	User-Set Options.....	5-1

Figures

Figure 2.1	DXP38 Rear Panel Connectors	2-2
Figure 2.2	Radio System Connections.....	2-3
Figure 2.3	Jumper J3 and J6.....	2-4
Figure 2.4	Typical M/S Mode Tuning Display	2-10
Figure 2.5	Typical Δf Mode Tuning Display.....	2-10
Figure 4.1	DXP38.EXE Main Screen	4-3
Figure 4.2	Main Menu Tree for CLOVER (left side).....	4-5
Figure 4.3	Main Menu Tree for ALL Codes (right side).....	4-6
Figure 4.4	Main Menu Tree for Baudot RTTY (left side).....	4-7
Figure 4.5	Main Menu Tree for ASCII RTTY (left side).....	4-8
Figure 4.6	Main Menu Tree for AMTOR (left side).....	4-9
Figure 4.7	Main Menu Tree for P-Mode (left side)	4-10
Figure 4.8	Configuration Menu - Page 1 (CLOVER & System) ..	4-12
Figure 4.9	Configuration Menu - Page 2 (HERE IS & HISCALL)	4-12
Figure 4.10	Configuration Menu - Page 3 (FSK Modes).....	4-13

FCC Statement

FCC RADIO FREQUENCY EMISSIONS STATEMENT

(Reference: CFR 47, Part 15)

U.S. Federal Communications Commission (FCC) Rules and Regulations, CFR47, Part 15, require inclusion of the following text in this manual.

INFORMATION TO THE USER (Section 15.105)

NOTE: This equipment has been tested and found to comply with the limits for a Class B digital device, pursuant to Part 15 of the FCC Rules. These limits are designed to provide reasonable protection against harmful interference in a residential installation. This equipment generates, uses and can radiate radio frequency energy and, if not installed and used in accordance with the instructions, may cause harmful interference to radio communications. However, there is no guarantee that the interference will not occur in a particular installation. If this equipment does cause harmful interference to radio or television reception, which can be determined by turning the equipment off and on, the user is encouraged to try to correct the interference by one or more of the following measures:

--Reorient or relocate the receiving antenna

--Increase the separation between the equipment and the receiver.

--Connect the equipment into an outlet on a circuit different from that to which the receiver is connected.

--Consult the dealer or experienced Radio/TV technician for help.

INFORMATION TO USER (Section 15.21)

The user is cautioned that any changes or modifications not expressly approved by the party responsible for compliance could void the user's authority to operate the equipment.

P-Mode

The word "P-Mode" is the HAL designation for a communications protocol that may also be known as "Pactor", a registered trademark of the Spezielle Communications Systeme GmbH (SCS) firm in Hanau, Germany. HAL affirms that, to the best of its knowledge, "P-Mode" is compatible and interoperable with the protocol SCS calls "Pactor" and with the link establishment mode of the protocol SCS calls "Pactor-II".

Chapter 1

Introduction

1.1 The DXP38 Manual

The DXP38 is the latest in the evolution of HAL DSP modem products that started with the PCI-4000. Operation, software, and control are very similar to that of the PCI-4000, P38, and DSP-4100 modems. Many of the same terminal programs used with these modems may also be used with the DXP38 with little or no changes. If you are already familiar with use of HAL DSP modems, please have a look at the instructions and diagrams of Chapter 2 and then jump right in.

Unlike previous HAL DSP modems, the DXP38 includes a hardware front panel tuning indicator that works with all terminal programs. The crossed-bar display is used for all data modes - RTTY, AMTOR, P-Mode, and CLOVER. The display may be switched between the normal M/S “+” tuning display and a zero-center tuning error scale. Use of the display for each mode is discussed in Chapter 2.

The DXP38 also includes **DXPWin**, a new HAL terminal program that runs under W95, W98, or NT4.0 Windows™ operating systems. The display format of DXPWin is very similar to the format of our DOS-based P38.EXE, PCC.EXE, and DSP41.EXE programs. You may not need much instruction to use this software, particularly if you are familiar with windows programs and if you have previously used the HAL DOS programs. However, a thorough reading of Chapter 3 is in order after “the new wears off”.

Our DOS-based terminal program, **DXP38.EXE**, is also included for all that wish to continue using PC-DOS. This is the popular and proven program HAL has included with all of our DSP modem products since 1993. Chapter 4 includes all of the operating details for those who may not have used this software or those of us who have forgotten a detail or two.

If you have problems, read Chapter 5, In Case of Difficulty. Sometimes, fixing a problem can be as simple as adding shielded wire; sometimes you need to send the modem to us for “heart surgery” or maybe it’s time for an “oil change and a lube job”!

Chapter 6 lists all of the fine-print specifications for those who like impressive numbers.

Be sure to read the Warranty. It is the standard HAL Warranty we have used for years. HAL stands behind its products. If you have a problem - LET US KNOW!

1.2 DXP38 Software

Your DXP38 package includes four (4) 3.5” diskettes. Three of these diskettes contain DXPWin, the windows-based terminal program. The remaining diskette contains DXP38.EXE, the DOS-based terminal program, and firmware that is used by the on-board microprocessors. Loading of DXPWin is discussed in Chapter 3 and loading of DXP38.EXE in Chapter 4. The firmware files on disk 4 will not be required unless the contents of the flash memory become damaged. Consult Chapter 5 to determine when reloading is necessary and how to reload the firmware.

1.2.1 Minimum Requirements

The DXP38 modem and its DXPWin or DXP38.EXE Software may be used with virtually any RS-232-equipped, IBM-compatible personal computer (PC). The serial port requirements are:

Connector (DXP38):	DE9P (male pins)
Data Format:	RS-232 levels with RTS/CTS hardware flow control
Data Rate:	9600 baud
Data Format:	No Parity, 8 bit data, 1 Stop bit (N-8-1)

The requirement on the PC itself is dependent upon whether the DOS or windows version of terminal software is used. Relatively old, slow, and inexpensive PC's may be used with DOS software; use of Windows requires a modern, fast, and relatively expensive PC. The minimum recommendations are:

DXPWin (use with Windows-95™, Windows-98™, or Windows-NT4.0™):

- PC-Pentium, 100 MHz
- 32 MB RAM
- 1 – 3.5" floppy disk drive
- 1 – hard disk drive (20MB free space minimum)
- VGA video card and monitor minimum

DXP38.EXE (use with PC-DOS):

- PC-AT or higher with MS-DOS or PC-DOS
- IBM-compatible ROM BIOS
- 640K RAM minimum
- 1 - 3.5" floppy disk drive
- 1 – hard disk drive (1MB free space minimum)

Third-Party Programs: If you will be using "Third-Party" terminal programs with the DXP38 (software not written by HAL), carefully read the documentation provided with the program and follow its instructions. Note that the DXP38 uses the same command set as the DSP-4100 modem. If "DXP38" is not listed as a modem option, try using "DSP4100" instructions. HAL Communications Corp. continues to work closely with a number of software authors and firms to provide additional user software. See our web page for links and a current list of "3rd Party" authors for CLOVER and DXP38 software.

1.2.2 Software and Documentation Up-Date

New versions of each program are available to all DXP38 owners as they are released by HAL Communications. Some software changes may also require changes to the documentation (manuals). Current copies of DXP38 software and documentation updates may be downloaded from our Internet web page at www.halcomm.com.

If you have problems or need additional information, please call:

Customer Service Manager

Voice: (217) 367-7373 (8AM - 5PM CST/CDT; Monday - Friday)
FAX: (217) 367-1701 (24 hours/day)

Chapter 2

Installation and Set-up

This chapter discusses how to connect the DXP38 modem to the radio system and to a PC terminal. Operation of the front panel tuning and status indications is discussed in section 2.4. Installation and use of HAL terminal software is presented in Chapter 3 (DXPWin for use with W95, W98, or NT4.0) or Chapter 4 (DXP38.EXE for operation under MS-DOS).

2.1 Unpacking and Inspection

The DXP38 system includes the following materials:

1 - 900-13800 Complete DXP38 product

This includes:

1 - 910-13800 DXP38 HF Modem
1 - 870-13800 DXP38 MANUAL
1 - 865-13810 DXP38-Disk #1 (DXPWin #1, Rev X)
1 - 865-13820 DXP38-Disk #2 (DXPWin #2, Rev X)
1 - 865-13830 DXP38-Disk #3 (DXPWin #3, Rev X)
1 - 865-13840 DXP38-Disk #4 (DXP38.EXE, DXP38.LOD & DXP38.S28, Rev x)
1 - 310-16032 DC Power Connector

When opening the DXP38 shipping carton, carefully inspect it for any evidence of shipping damage. Any damage should be immediately reported to your shipping carrier. Be sure to save any damaged packing materials. Note that a damage claim must be filed by you with the shipping carrier - NOT HAL Communications. HAL will be glad to assist in such cases, but only the shipping carrier can pay claims.

Check to be sure that all of the materials listed above are contained in your DXP38 package. If you find any materials missing, please contact your dealer or HAL Communications as soon as possible.

2.2 DXP38 Rear Panel Connections

The rear panel of the DXP38 modem is shown in Figure 2.1 and the limits for each I/O signal are shown in Table 2.1. These requirements are compatible with all modern amateur transmitters and receivers. **DO NOT EXCEED THESE LIMITATIONS.**

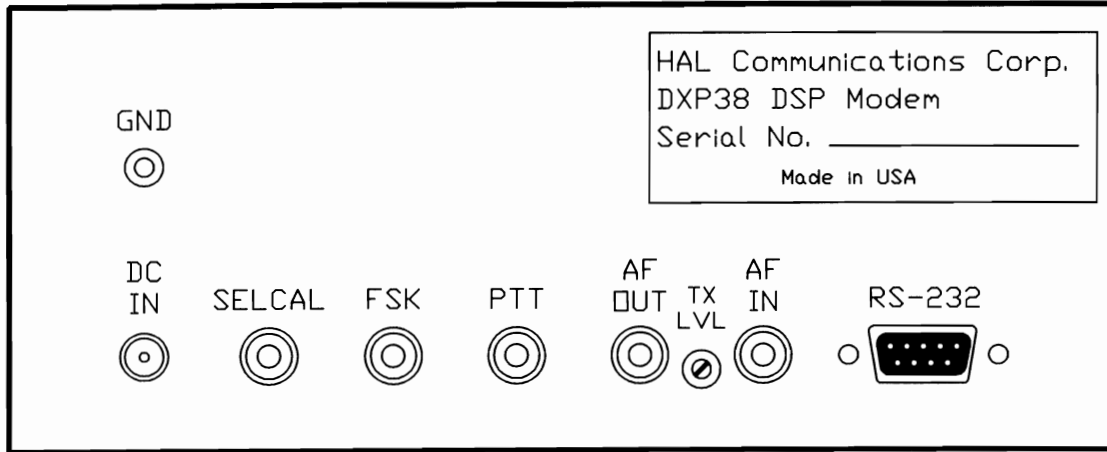

Figure 2.1 DXP38 Rear Panel Connections

**Table 2.1
DXP38 I/O Connections**

CONN	FUNCTION	I/O	LIMITS
AF IN	Audio from RX	Input	5V p-p
AF OUT	Audio to TX	Output	-30dBm (25 mV)
PTT	Push-to-Talk Output	Output	+50V @ 100 ma
FSK	FSK Output	Output	+50V @ 100 ma
SELCAL	SEL-CAL Output	Output	+50V @ 100 ma
DC IN	DC Power Input	Input	+9 - +18V @ 0.6A
GND	RF Ground	Ground	
RS-232	Data	I/O	+/-15 VDC

Typical connections of the DXP38 to radio station equipment are shown in Figure 2.2.

2.2.1 Audio Input

The DXP38 Audio Input (AF IN) is unbalanced. The Input impedance is 10,000 ohms, $\pm 10\%$. This input can be directly connected to a wide variety of receiver audio output terminals including low-impedance speaker (4 - 16 ohms), line (600 ohms), headphone (2K ohms) or "recorder output" (10,000 ohms). A matched terminating resistor is not required. The maximum audio input voltage to the DXP38 should not exceed 5 volts peak-to-peak (1.7V rms; +7 dBm). The DXPWin and DXP38.EXE terminal programs include tuning indicator bars which may be used to adjust the receiver output volume.

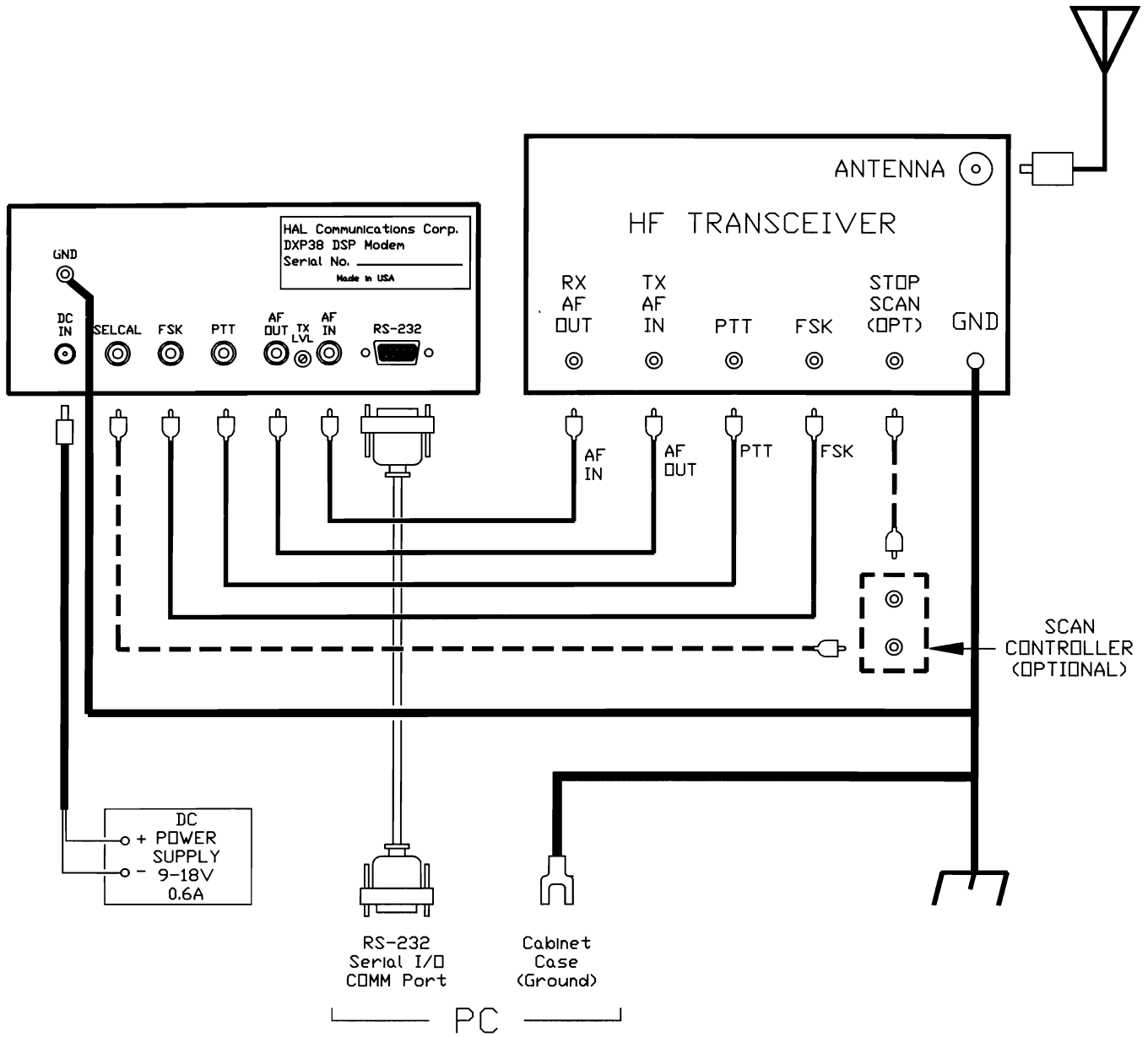

Figure 2.2 Radio System Connections

2.2.2 Audio Output

The DXP38 Audio Output (AF OUT) is also unbalanced. The nominal output impedance is 600 ohms but AF OUT does not require a termination load. It may be connected to a wide variety of transmitter audio input terminals including microphone (low or high-impedance), "phone patch", or "line (600 ohm)". The AF OUT circuit includes a 1uF series capacitor to prevent DC loading of transmitter microphone inputs that have a DC bias voltage.

Jumper J3 on the circuit board (see Figure 2.3) sets two output voltage ranges. The exact level may be set via the rear panel TX LVL adjustment. The output ranges are shown in Table 2.2.

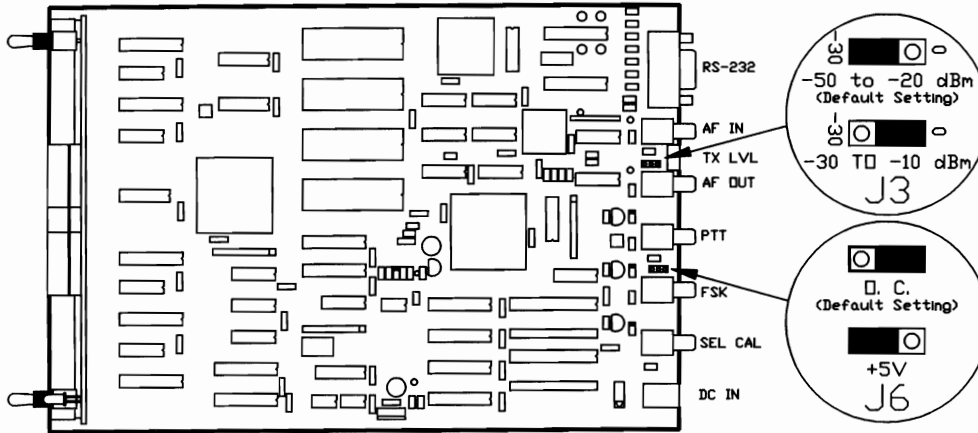

Figure 2.3 Jumper J3 and J6

**Table 2.2
AF OUT Voltage Ranges**

J3	Nominal Output Voltage	Adjustment Range
Open	-30 dBm (25 mV rms)	-50 to -20 dBm (2.5 to 78 mV rms)
Closed	-10 dBm (250 mV rms)	-30 to -10 dBm (25 to 250 mv rms)

All DXP38 units are shipped with jumper J3 in the -30 dBm position and the rear panel output control set for -30 dBm. This output voltage will be correct for use with microphone (or "phone patch") inputs of most HF SSB transmitters. J3 should be changed to the "Closed" position when the DXP38 is connected to transmitters that require a high-level transmit audio input. Proper adjustment of the TX LVL control is discussed in section 2.3.

IMPORTANT CONSIDERATION WHEN USING CLOVER: The DXP38 has an "FSK Output" that may be used for AMTOR, P-Mode and RTTY. However, the CLOVER-II waveform cannot be generated when transmitters are operated in an "FSK" mode. The transmitter should be operated in LSB mode and the CLOVER-II transmit audio tone signal must be connected to the transmitter audio input.

2.2.3 PTT Output

The DXP38 provides TX/RX control of the radio equipment via the PTT (Push-To-Talk) transistor output on the rear panel. This is shorted to ground to transmit and is open circuit when receiving. The TX/RX PTT circuit should have a positive polarity with a maximum open-circuit voltage (RX state) of 50 volts DC and a maximum closed circuit current (TX state) of 100 ma DC.

2.2.4 FSK Output

FSK OPTION SELECTION: The DXP38 FSK output circuit may be used with many modern HF transceivers that include an FSK input to transmit RTTY, AMTOR, or P-Mode. However, as previously noted, CLOVER cannot be transmitted using the transceiver FSK input. A "universal" FSK interface standard for HF transmitters does not exist between manufacturers or between models made by the same manufacturer. Four FSK interface options may be selected that support those FSK standards we have encountered. If you have additional information regarding FSK inputs, we would appreciate your comments.

The FSK output is an NPN transistor which can be set for open collector (O.C.) or pulled up to + 5 Volts D.C. (+5V) by setting jumper plug J6 (see Figure 2.3). The factory default setting is to O.C. (Open Collector). The polarity of the FSK output is selected from the operating program (DXPWin or DXP38.EXE). See Chapters 3 and 4 to access this parameter on the Configuration menu. The factory default setting is to Normal polarity.

Some transceivers require a switch to ground on the FSK input. In this case, use the O.C. (Open Collector) setting for J6. Other transceivers require a voltage on the FSK line. In this case, use the +5V setting for J6. Table 2.3 summarizes the four possible combinations of DXP38 FSK output signal. Table 2.4 lists the correct FSK combinations for a few transceivers.

Table 2.3
DXP38 FSK Output Options

POLARITY	J6	MARK	SPACE
NORM	O.C.	0V	Floating
REV	O.C.	Floating	0V
NORM	+ 5V	0V	+ 5V
REV	+ 5V	+ 5V	0V

Table 2.4
FSK for Typical Amateur Transceivers

MFGR	MODEL	POLARITY	J6
TEN-TEC	CORSAIR	NORM	+5V
TEN-TEC	PARAGON (585)	NORM	+5V
TEN-TEC	OMNI (582)	NORM	+5V
KENWOOD	TS-180	NORM	O.C.
KENWOOD	TS-440	NORM	+5V
KENWOOD	TS-930s	REV	O.C.
KENWOOD	TS-940s	NORM	O.C.
ICOM	IC-730	REV	O.C.
ICOM	IC-740	REV	O.C.
ICOM	IC-745	REV	O.C.
ICOM	IC-751	REV	O.C.
ICOM	IC-761	REV	O.C.
ICOM	IC-781	REV	O.C.
YAESU	FT-101ZD	NORM	O.C.
YAESU	FT-107	NORM	O.C.
YAESU	FT-910/902	NORM	O.C.
YAESU	FT-980	NORM	O.C.
YAESU	FT-ONE	NORM	O.C.

This data is based on reports from HAL customers and some manufacturers. HAL would like to know of any other information you may have concerning FSK inputs. A careful reading of your transceiver manual or a call to the manufacturer's "Customer Assistance Department" may be required to determine which interface level is required for your equipment. If your transceiver is not listed or you have some doubts about the required level or polarity, try the following:

1. Start with NORM polarity and set to J6 O.C. (factory default settings).
2. Try sending simple FSK RTTY to a friend with a working RTTY station.
3. If you cannot send Mark/Space RTTY, the J6 setting may be wrong. Try setting J6 to +5 V.
4. If you can send FSK, but it is upside down, change the polarity to REV.

Note: This information is offered as a service to our amateur customers only. HAL cannot guarantee performance for FSK mode nor be held responsible for any damage that may result from connection of voltages to a transceiver "FSK" input jack. If you have any doubts, please contact the transceiver manufacturer before making any connections.

2.2.5 SEL-CAL Output

The SEL-CAL output of the DXP38 is an open-collector NPN transistor (MPS-A42) that switches to ground during an ARQ link. This signal may be used to signal that the station has been called and linked in ARQ mode or to control frequency scanning radio systems. The rating of the switching transistor is +50 VDC maximum (open circuit) and 100 ma DC maximum (closed circuit).

The SEL-CAL output is normally open ("high") until the call sign of the local station (MYCALL) is recognized during an ARQ link request. When MYCALL is recognized, the SEL-CAL output shorts to ground ("low"). Options in DXPWin and DXP38.EXE allow selection of two modes to match switching requirements of various radio models. The modes are "CONTinuous" and "PULSE".

In the CONTinuous SEL-CAL mode, the SEL-CAL output signal remains in the "low" state throughout the ARQ link. The signal will revert to "high" when the ARQ link is terminated at disconnect.

In the PULSE SEL-CAL mode, the SEL-CAL output signal will pulse "low" for 2 seconds when MYCALL is recognized, remains "high" during the ARQ link, and will again pulse "low" for 2 seconds when the ARQ link is broken (disconnected).

The interface wiring to the SEL-CAL output varies widely with radio manufacturer and model. Detailed connection information should be obtained from either the radio manufacturer or from other radio operators who have made successful scan-control interfaces to their radios. At this writing, none of the commercially available amateur radio transceivers provide a rear-panel scan-control input connection - all makes and models require modification.

While HAL warrants the operation of the SEL-CAL output signal to be as described above, this warranty does not extend to the functionality of use of the SEL-CAL signal with other equipment. Further, HAL must disclaim any damage to the radio equipment or to the DXP38 which may result as a consequence of user modification of his radio equipment.

2.2.6 RS-232 Connections

All data connections to your computer terminal are made via the 9-pin RS-232 connector. These connections follow industry standards and pre-manufactured cables may be used to connect between the PC's serial I/O port and the DXP38. If you are writing your own software for the DXP38, please contact HAL and request a copy of HAL Engineering Documents E2001 and E2005. The signal connections are described in Table 2.5.

Table 2.5
RS-232 Data I/O Connections

PIN	LABEL	SIGNAL	OPERATION
1	DCD	Data Carrier Detect	High = Signal detected
2	RXD	Receive Data	Demodulated receive data
3	TXD	Transmit Data	Data to be transmitted
4	DTR	Data Terminal Ready	High = PC is ready
5	GND	Ground	Ground
6	DSR	Data Set Ready	High = DXP38 is ON
7	RTS	Request To Send	High = RXD Flow Control
8	CTS	Clear To Send	High = TXD Flow Control
9	N.C.	no connection	

2.2.7 Ground Connection

It is very important that low-resistance RF ground connections be made between all units of the radio transmit / receive station. Otherwise, transmitter RF interference (RFI) may severely limit operation of the PC or the DXP38 modem. Similarly, high-frequency noise from the computer or modem may cause severe interference when receiving. Ground connections should be short and have low resistance and low inductance. Shield braid that is at least ¼" wide is recommend for all RF ground connections.

2.2.8 DC Power Connection

The DXP38 may be operated from any DC power source that is filtered (free of hum and noise) and relatively stable (short-term voltage fluctuations less than $\pm 10\%$). The voltage output of the power source should be between 9 to 18 VDC. Note that the positive terminal connects to the center pin. The DXP38 requires approximately 250 ma during normal operations, but reloading the flash memory requires approximately 500 ma. Be sure to use the DC power connector supplied with the DXP38 or obtain an exact copy. There are many versions of the coaxial power plug offered for sale and most "look similar" but may not be reliable. Contact HAL if you need a new or an additional power connector.

2.3 Initial Transmitter and Receiver Adjustment

The following procedure describes how to test the DXP38 with your radio equipment and make initial adjustments. The set-up and test procedures used with DXP38.EXE are described below but you may also wish to review your desired program in more detail (Chapters 3 and 4).

These adjustments take advantage of the "Test Mode" of CLOVER but the settings obtained apply to all modes – RTTY, AMTOR, P-Mode, and CLOVER.

1. Connect the DXP38 AF IN, AF OUT, and PTT to the HF Radio Equipment. Disconnect the microphone and any other transmitter audio inputs.
2. Connect the DXP38 RS232 connector to the PC's serial I/O connector.
3. Set the receiver and transmitter controls as follows:
 - a. BAND = convenient "RTTY frequency"
 - b. Mode = LSB
 - c. RX AF OUT = 25% of maximum
 - d. RX FILTER = "Voice"
 - e. RF OUT = dummy load
 - f. TX AF IN (MIC GAIN) = minimum
 - g. TX RF OUT = minimum

- h. TX ALC and COMPRESSION = OFF
 - i. TX VOX = OFF
 - j. RIT / XIT = OFF
 - k. Antenna = dummy load
4. Load DXPWin or DXP38 (see Chapter 3 or 4)
 5. Turn PC power ON and let it boot.
 6. Select CLOVER mode.
 7. Turn Transceiver AC power ON.
 8. Adjust RX AF GAIN control until amplitude bars show movement on noise.
 9. Enter TX TEST mode.
 10. Type the **[Space bar]** to set single-tone test and turn the transmitter ON.
 11. Slowly increase the MIC GAIN control (and TX RF OUT control if necessary) until the desired full RF output power is obtained. Watch the ALC meter and/or light; set the RF Output to *just below* the level at which ALC control starts. DO NOT CHANGE THIS MIC GAIN SETTING. See step 15 if the MIC GAIN control must be set at the extreme low end of its range (near counter-clockwise end).
 12. Switch the transceiver meter to read RF output and note the reading. This is the peak power output of your transmitter when using CLOVER-II.
 13. Type the **[Space bar]** again to enable four-tone test mode. Note the new reading of the RF Output meter. This is the average power output of your transmitter.
 14. Type **[Space bar]** once again to turn the transmitter OFF. Type **[Alt]-O** or **[Esc]** to exit TEST mode.

The difference in RF output measured in steps 12 and 13 varies greatly with the make and model of the transceiver and the design of the Wattmeter circuit. Some meters may show no difference; others may show as much as a 4:1 (6 dB) difference. The exact meter readings are not critical. However, it is very important that the adjustment in step 11 sets the maximum non-ALC controlled power output level of the transmitter.

IMPORTANT: Do *not* increase the transmitter microphone gain control setting beyond that set in step 11. While this might cause the RF output meter to read higher output power, it will also assure that your transmitted CLOVER signal is distorted and degrades system performance. Over-driving may also result in wide-bandwidth "splatter".

15. The DXP38 transmit audio output level may be adjusted with the screwdriver set TX LVL control on the rear panel. This control is set at the factory to its maximum output position. If the setting of the MIC GAIN control determined in step 10 is very low (near the CCW end), set the DXP38 rear panel control to the middle of its range and then repeat steps 10 through 14. This will reduce the output from the DXP38 and increase the setting of the transmitter's MIC GAIN control. Use the highest setting of the DXP38 control that produces a usable setting of the transmitter's MIC GAIN control to minimize "hum" and noise on the modulation.
16. Some transceiver models (IC-735 and possibly others) include a rear panel transmit audio input but that its level is not adjustable by the front panel MIC GAIN control. If this input is used, transmitter

power level adjustments must be made using the DXP38 rear panel control as noted in #15. It may be simpler to connect directly to the front panel microphone jack of these transceivers.

2.4 Front Panel Status and Tuning Indicators

2.4.1 Status Indicators

The vertical line of six LED's on the DXP38 front panel shows the modem status. Their function is described in Table 2.6.

Table 2.6
DXP38 Status Indicators

LABEL	DESCRIPTION
RX	On when receiving. Flashes in ARQ modes when linked.
TX	On when transmitting. Flashes in ARQ modes when linked.
ERR	On when Errors are detected in ARA modes.
LINK	On when linked in ARQ modes
CALL	On when calling in ARQ modes
STBY	On when in standby in ARQ modes

In any mode condition, one of the six LED's will be on if power is turned on.

2.4.2 Tuning Indicator – M/S Mode

The DXP38 uses a crossed-line LED bar display to aid when tuning the receiver. This display may be set to two different tuning modes by the front panel M/S and Δf switch. When the "M/S" display mode is set, the tuning bar functions much like the familiar crossed-ellipse oscilloscope display. In FSK modes (RTTY, AMTOR, and P-Mode), the horizontal bar shows the signal amplitude from the "Mark" filter and the vertical bar shows the "Space" amplitude. Correct FSK mode tuning is achieved when both bars show maximum length.

The M/S mode also shows filter amplitudes when tuning CLOVER but each bar segment now shows the amplitude in the four CLOVER tone filters. Optimum tuning is indicated when all four bars have maximum length from the center out. Note that CLOVER tuning data is updated only every 2 seconds. Receiver tuning adjustments must therefore be made *very* slowly and gently! Typical tuning displays for M/S mode for FSK and CLOVER modulations are shown in Figure 2.4.

2.4.3 Tuning Indicator - Δf Mode

The tuning display may also be used to determine the exact tuning error when receiving FSK and CLOVER modulation. In this case, the horizontal bar becomes a zero-center frequency error display. Each horizontal bar segment ("dot") corresponds to a tuning error of approximately 5 Hz, providing a tuning indicator range of ± 50 Hz. Deflection of a dot to the left of center indicates a negative tuning errors (below correct frequency), to the right a positive tuning error (signal tuned too high). The vertical bar is used to emphasize fine-tuning with a total range of just ± 20 Hz from no display to full scale. The vertical display shows a continuous bar that increases in length as correct tuning is approached. When the signal is tuned *exactly* to match the DXP38 receive filters, the center LED and all of the vertical LED bar segments are turned on. The frequency tuning mode is slower to respond than when the M/S mode is used. Tune slowly and pause a second or two between each receiver adjustment. Tuning conditions for Δf mode are shown in Figure 2.5.

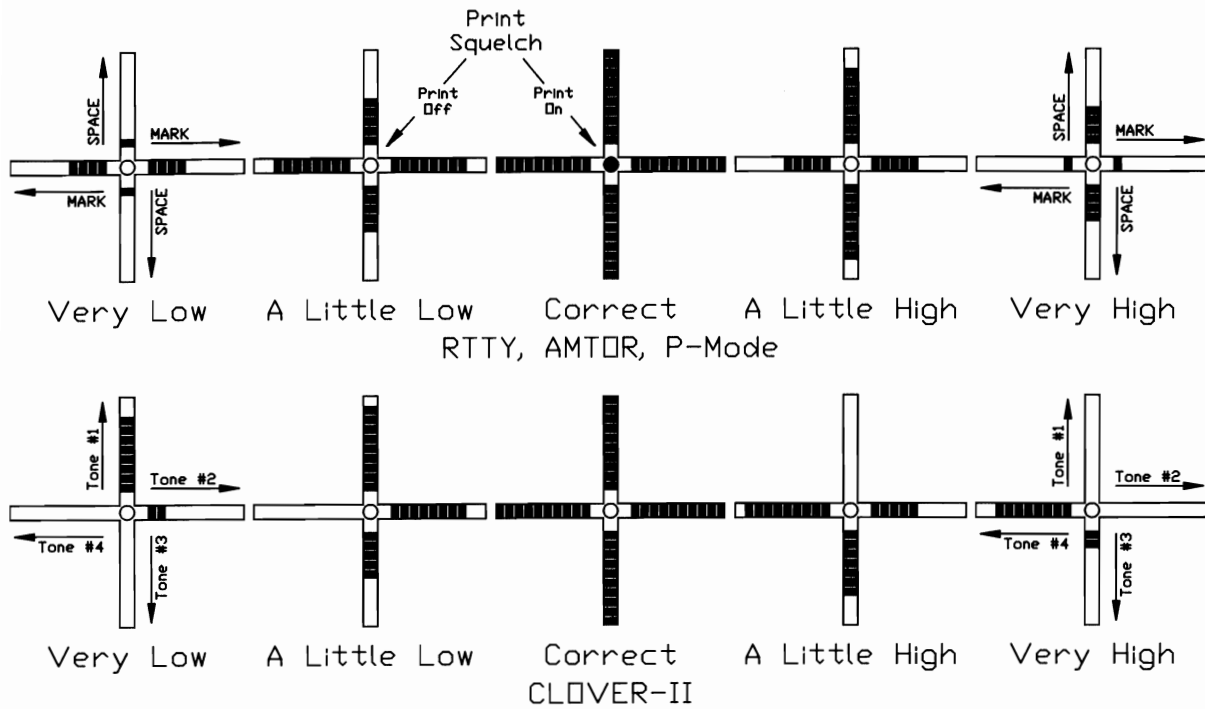

Figure 2.4 Typical M/S Mode Tuning Display

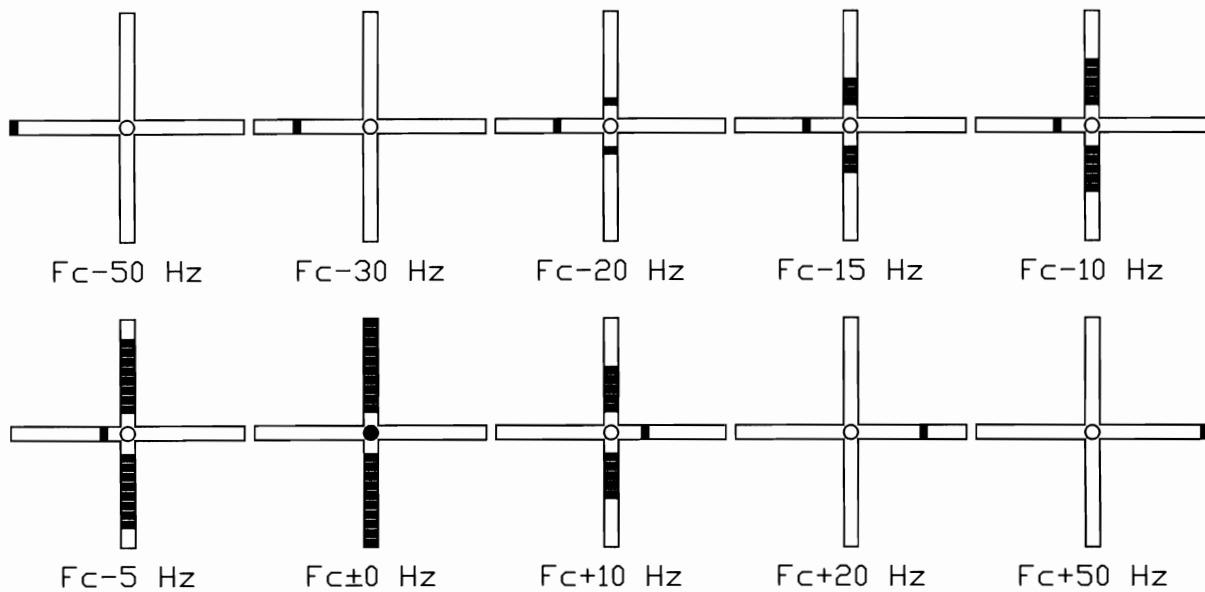

Figure 2.5 Typical Δf Mode Tuning Display

2.4.4 Print Squelch Indicator

In Baudot and ASCII RTTY modes and when the tuning indicator is set to show "M/S", the center LED of the "X" shows RTTY Print Squelch condition. This center LED will be ON when the signal exceeds the print squelch threshold and receive signals can be "printed" (displayed on the PC screen). This LED will also be turned ON when the Print Squelch feature is turned OFF as all signals and noise are passed to the PC in this case. Print Squelch status is shown only for Baudot and ASCII RTTY and only when the tuning indicator is set to M/S mode.

2.5 Special Considerations When Operating CLOVER

The DXP38 and CLOVER-II waveform may be used with most HF SSB transmitters and receivers. HF equipment used with the DXP38 and CLOVER-II should meet or exceed the requirements shown in Table 2.6. The more important radio parameters are discussed in the following sections. If you desire additional information about CLOVER-II, request a copy of HAL Engineering Document E2006 and the latest CLOVER Bibliography list.

2.5.1 Transmitter & Receiver Requirements

CLOVER-II waveform uses multiple tones and phase-shift modulation. Performance is best when the transmitter and receiver frequencies match exactly. CLOVER will link and communicate when tuning errors are as great as ± 30 Hz. However, tuning should be within ± 10 Hz to obtain top performance at the highest data rate modulation modes. Therefore, the radio equipment should be tunable in at least 10 Hz tuning increments and in finer increments if possible. Receivers whose frequency may be adjusted in 1.0 Hz increments are ideal for use with CLOVER.

It is also very convenient if the transmitter and receiver frequency dials have 10 Hz or even 1 Hz resolution. This is particularly true for network operation. Tuning aids such as the on-screen-tuning bars are essential to obtain full performance from CLOVER. Dial calibration accuracy is not essential for proper CLOVER operation - but is very useful for reliable network operation.

The frequency stability of the transmitter and receiver should be as high as possible. Frequency stability within ± 5 Hz per hour is desirable for manually controlled stations. Long-term stability of ± 10 Hz is advised for automated network applications. The "High Stability" option offered for many transmitters, receivers, and transceivers is recommended for automated network stations.

TABLE 2.7
CLOVER-II HF RADIO REQUIREMENTS

PARAMETER	REQUIREMENTS
Tuning Increments	10 Hz
Frequency Stability	± 20 Hz/hr
Frequency Accuracy	± 10 Hz
TX/RX Mode	LSB (not "FSK")
Receiver Filter	"Voice" bandwidth
TX/RX ON/OFF time	32 ms
TX Audio Input	-10 dBm to -30 dBm
RX Audio Output	Speaker or Line
RX Output Impedance	10,000 ohms or less
Phase Linearity	Not Critical
TX ALC	OFF
TX Compression	OFF
RX AGC	SLOW (not Fast)
RX Noise Blanker	OFF or min level required

2.5.2 Receiver Tuning of CLOVER-II Signals

The CLOVER-II signal is very unique and unlike any HF data signal previously used. The CLOVER-II waveform is made up of four tone pulses that are sent sequentially in time. The phase and amplitude of each tone is changed when transmitting data. When tuned on a receiver, the CLOVER signal sounds something like an electronic telephone ringer ("bell"). We say CLOVER has a "twitter" sound.

Accurate tuning of the received CLOVER signal is very important. Receiver tuning should be within ± 30 Hz of the correct frequency and with ± 10 Hz for optimum operation. Receiver adjustment to these tolerances requires an accurate tuning indicator and generally cannot be done "by ear".

CLOVER continually computes an internal phase and frequency reference from the received signal and uses these references to (1) detect data, (2) measure and compensate for ionospheric variations, and (3) compensate for tuning inaccuracy and frequency drift between the two stations. It requires approximately 2 seconds of integration to obtain the necessary frequency and phase accuracy. Because of this required integration time, it can be very destructive to adjust the receiver frequency once correct tuning has been found and CLOVER demodulation has begun.

Therefore the following GOLDEN RULES should be followed.

1. Tune slowly and accurately.
2. When correct tuning is achieved, get your hand off the knob!
3. Keep your hands off the tuning knob (Lock the dial if necessary).

2.5.3 Transmit Modulation

CLOVER-II is a "J2" emission - it is an audio waveform that must be connected to the audio input of an SSB transmitter. CLOVER does not use the "FSK" transmitter feature of some HF transceivers. Either USB or LSB may be used with CLOVER, but we recommend LSB to be compatible with conventions used by other HF data modes.

2.5.4 Receiver AGC and Noise Limiter

Receiver AGC (or AVC) may also cause a demodulation and distortion effect like that described for transmitter ALC. However, receiver AGC also prevents overload of the receiver by strong signals. In most situations, it is recommended that SLOW receiver AGC be used to receive CLOVER signals. However, non-manned automated stations should always use AGC set to the SLOW mode.

Noise limiters and/or blankers should be used as little as possible as they are also amplitude leveling devices. A good noise blanker may be used in severe conditions, but it should be turned OFF as soon as conditions permit.

2.5.5 Receiver Filters

The -50 dB bandwidth of the CLOVER-II spectra is 500 Hz. The audio center frequency is normally set to 2250 Hz, producing a -50 dB audio spectrum from 2000 to 2500 Hz. This spectra is similar to that occupied by "high-tone AFSK" RTTY/AMTOR signals. However, unlike RTTY/AMTOR modems, the DXP38 uses very precise and "sharp-skirted" digital filters that match the transmitted CLOVER spectra. In addition, the DXP38 uses a 14-bit A/D (analog-to-digital) converter with a dynamic range of approximately 80 dB. The DSP filters within the DXP38 are therefore optimized for CLOVER and will generally be considerably better than those used in the receiver. In most cases it is not necessary to use a narrow IF filter in the receiver. The standard 2.1 to 2.7 kHz wide "voice filter" is quite adequate for CLOVER reception.

The high dynamic range of the CLOVER DSP modem filters will handle most conditions, including strong adjacent channel interference. However, a narrow receiver filter may be useful at times to prevent receiver overload from extremely strong adjacent channel interference but it may *not* improve CLOVER reception due to distortion added by the filter. Use narrow filters sparingly and only when required to reduce receiver overload. Filters as narrow as "500 Hz" may be used, but if a choice is available, a slightly wider filter is much preferred over one that is "slightly too narrow". A "600" or even "900" Hz filter will give similar performance and be easier to use than a "500 Hz" wide filter. The following adjustment procedure is recommended when narrow receiver filters are used.

1. Establish a CLOVER ARQ link using the "voice bandwidth" receiver filter.
2. Carefully adjust receiver tuning to reduce frequency offset as much as possible. Use the amplitude bar display to "get close" and then change to the frequency display. Slowly adjust the receiver frequency to reduce the frequency error to be as close to "zero" as possible. Lock the tuning dial to prevent accidental miss-adjustment.
3. Display the amplitude tuning bars.
4. Change to the narrow receiver filter and adjust the "pass-band tuning" (PBT) control for a "symmetrical" display of the four tone amplitudes. For example, when properly adjusted, a 500 Hz filter will add some attenuation to both tones "T1" and "T4". Adjust PBT so that the T1/T4 attenuation is the same. Note this setting of the PBT control and always use it for CLOVER reception. Over the short term, the amplitudes of the four tones will vary up and down, showing the effect of selective fading. The PBT should be set so that "on-average", the four tone amplitudes are symmetrical.

2.5.6 Receiver Audio Level

The DXP38 is designed to work with common audio levels that may be obtained from modern HF communications receivers. The amplitude tuning bar display on the PC screen clearly shows the maximum audio level input. Adjust receiver audio volume so that average received signals are below the "MAX" line on the screen.

The DXP38 has a wide dynamic range input and will work well even if the receiver output is low. The scale of the amplitude tuning bar display is intentionally expanded. Receiver audio level is not critical and good performance will be obtained when the amplitude bars are in the upper half of the display. Increasing the volume control will not improve reception! The following procedure will help determine a good receiver volume control setting for your equipment. When receiving noise (no signals), adjust receiver volume until the four amplitude bars vary on noise over the lower 1/4 of the scale.

2.5.7 Adaptive Control and Radios

CLOVER ARQ mode automatically adapts to changing ionosphere conditions. This is a unique feature of CLOVER and a major reason why it works so well for HF radio data communications. However, adaptive control may at first appear to cause some confusing operations. Please consider that when linked in ARQ mode, my CLOVER modem analyzes your received signal. My modem then signals to your modem which transmit modulation mode will be most effective under current conditions. Your modem then uses that modulation for the next data transmission to me. In other words, your transmitter modulation mode is under control of the other station and is not set by you.

Chapter 3

OPERATION UNDER WINDOWS

This Chapter provides information on how to install and use DXPWIn, the DXP38 Windows 95/98 based terminal program. Please refer to section 1.2.1 before installing DXPWIn. This section discusses the minimum hardware requirements necessary to run DXPWIn. If your system does not meet these requirements or you are unsure about your system, refer to Chapter 4 Operation under DOS. Chapter 4 discusses DXP38.EXE, the DOS terminal program which does not require the same system requirements.

DXPWIn has been designed for typical installation on a Windows 95/98 Operating system. If you are not familiar with standard Windows 95/98 installations, read each step carefully. This Chapter is designed to provide simple instructions on how to install and run DXPWIn, but it is not the intent of this manual to provide Windows Operating System support. If you have problems running DXPWIn and meet the DOS system requirements (section 1.2.1), install DXP38.EXE (Chapter 4) to verify proper installation and set-up. If you still have problems, please consult Chapter 5 (In Case of Difficulty).

DXPWIn provides access to all of the features and modes of the DXP38. However, many other third party terminal and control programs have been written for the DXP38 modem and you should consult their manual for operation. If you choose to run a third party software program, it is recommended that you also install DXPWIn or DXP38.EXE (Chapter 4) to verify proper hardware set-up.

3.1 Installing DXPWIn Software

After checking all of your connections and verifying that you meet the minimal system requirements, it is time to install DXPWIn.

Installation of DXPWIn closely follows most standard Windows installation programs. Although you may be familiar with Windows installation programs, please follow each step closely to ensure standard installation. Before beginning installation close any running applications.

Use the following steps to start the DXPWIn installation program.

- 1 Turn on your PC
- 2 Put your Installation Diskette 1 in Drive A:
- 3 Click 
- 4 Click 
- 5 The Run Window appears. TYPE:
A:SETUP
- 6 Click: **OK**.
- 7 The DXP38 Set-up program will now begin.

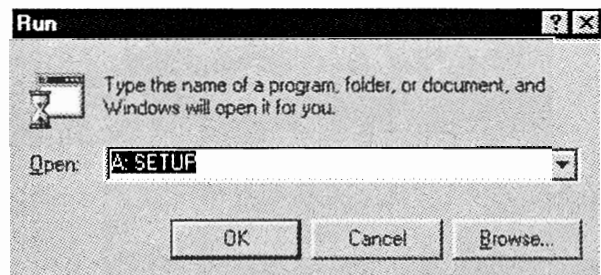

3.1.1 The DXPWin Setup Window

Begin installation by clicking: **OK**

If you have open applications running, click: **Cancel**. You must close all open applications and start DXPWin Setup again. You will be prompted as installation files are removed from your system. To continue with the installation click: **Next**

3.1.2 Changing DXPWin Directory

For standard installation, you do not have to change the installation directory. If you wish to install to a different drive or directory click: **Browse**. You will be prompted to type a new directory and/or drive location. When finished, click: **OK**

3.1.3 Installing Files

DXPWin now asks you to specify the location of the program Icons. Click **Next** to select the default location or type in your own custom name and then Click **Next**.

DXPWin Setup will now ask for you to review your previous choices before installing files. Choose **Back** to make any changes and **Next** to continue.

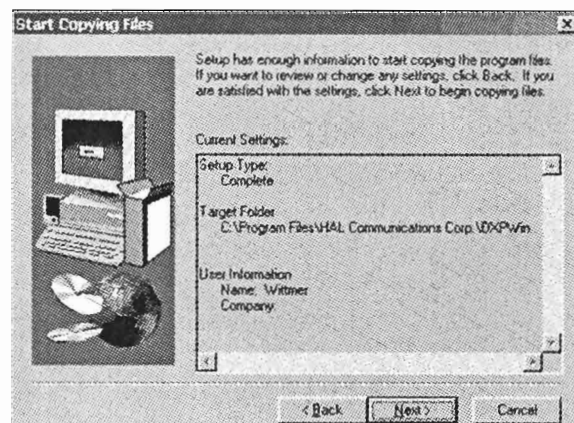
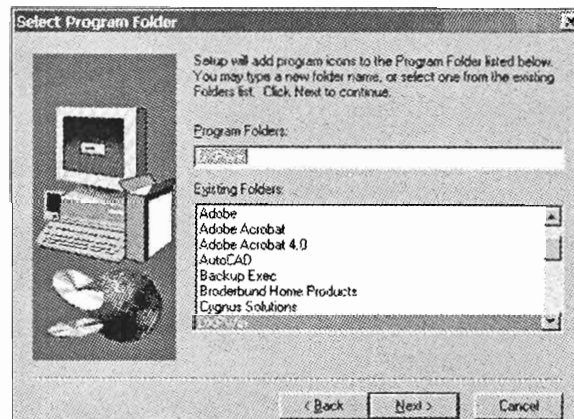
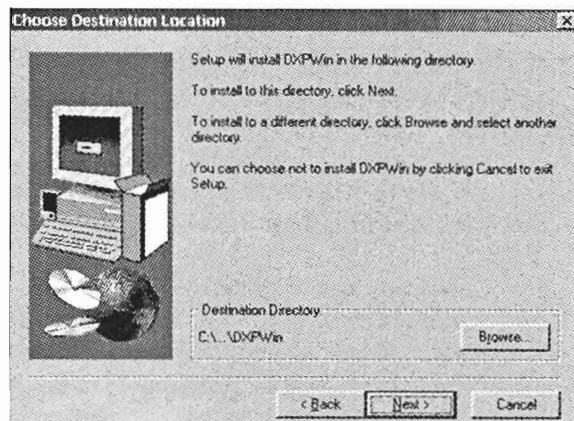
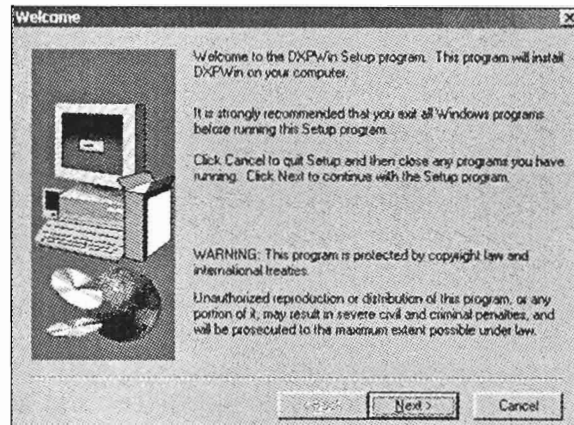

DXPWin Setup will now begin to copy files to your hard drive. You will be prompted to insert Disk 2 in Drive A: then Click: **OK**.

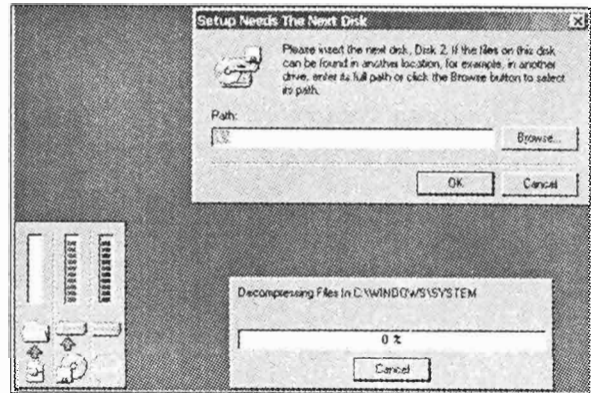

The DXPWin Setup “Setup has finished copying files to your computer” message should appear when completed. click: **OK**

Setup is now complete. It is recommended to restart your computer before proceeding with the installation. To restart your PC Click: **Finish**

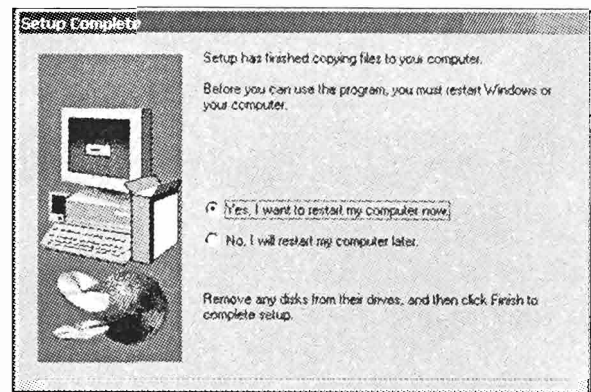

3.2 Manual Conventions

The following manual conventions describe the method of pressing certain key presses.

1. All user-entered keystrokes or mouse clicks are in **BOLD** print.
2. Multi-letter keytop labels are shown in [BRACKETS]. For example: **[ENTER]**, **[F1]**, **[F8]**, **[Ctrl]**, **[Alt]**, **[Shift]**, **[Home]**, **[PgUp]**, etc. Each **[BRACKETED]** set represents one key to be pressed.
3. Some keys must be held down while pressing a second key. These will be shown with a dash (-) between key presses. The combination of these keypresses is also known as a hot key.

For example: **[Alt]-C** This notation should be interpreted as:
 press and hold the **[Alt]** key
 press and release the C key
 release the **[Alt]** key

DXPWin utilizes the following special keys:

FUNCTION KEYS

<u>KEY</u>	<u>Fn</u>	<u>Alt-Fn</u>	<u>Ctrl-Fn</u>
F1
F2	Send CALL + ID
F3	Send CALL	...	Change HISCALL
F4	Send ID	Force CW ID	...
F5	Send HERE IS #
	Here IS (CLOVER)
F6	OVER (TOR)
	NORM/REV(RTTY)		
F7	Normal End	Panic Kill (CLOVER)	...
F8	Listen ON/OFF	Tone Test	...
F9	Connect/Call	Call CQ (CLOVER)	AF Channel (CLOVER)
F10	TX Enable ON/OFF	TX Enable ON/OFF	TX Enable ON/OFF

HOT KEYS

<u>KEY</u>	<u>FUNCTION</u>	<u>KEY</u>	<u>FUNCTION</u>
Alt-A	Date (MARS Format)	Alt-N	Toggle NORM/REV
Alt-B	Send Time and Date	Alt-P	Print Squelch
Alt+F	Files (Save)	Alt-Q	Send QBF Message
Alt-G	Force Letters	Alt-R	Select RTTY Rate
Alt-H	Help Pages	Alt-T	Send Time (MARS Format)
Alt-I	CW ID ON/OFF	Alt-U	Clear RX Buffer
Alt-M	Change MYCALL	Alt-X	Clear TX Buffer
		Alt-Z	Send MARS Time Group

EDIT KEYS

<u>KEY</u>	<u>FUNCTION</u>	<u>KEY</u>	<u>FUNCTION</u>
PgUp	Move up one page	Ctrl-Home	Move to line 1 column 1
PgDN	Move down one page	Ctrl-End	Move to last line in TX buffer
Home	Move to beginning of line	Ins	Toggle Insert and Overstrike
End	Move to end of line		

3.3 Running DXPWin

Now that you have DXPWin installed correctly it is time to run the software. First, make sure the modem is turned on and verify the COM port setting you are using on your PC. You will be asked for that information shortly.

To run DXPWin you must find its icon in the Start menu Programs\DXPWin folder.
Click: **DXPWinC**

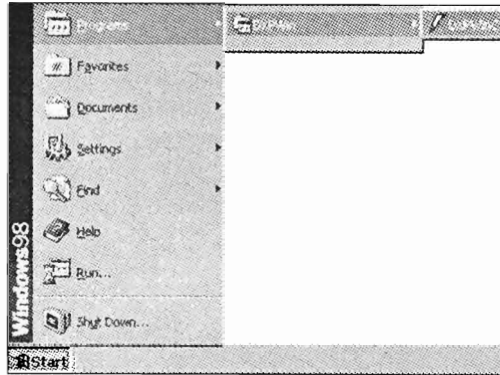

DXPWin will now begin with a window requesting that you provide the correct COM Port setting for the DXP38. You may wish to save this setting in your configuration file (see section 3.6.4 Configure Menu) after DXPWin has found the DXP38 modem.

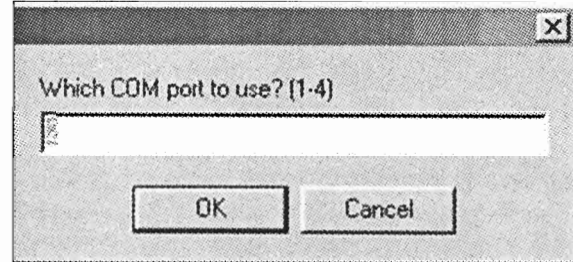

3.4 MYCALL Setup

MYCALL is the call sign of the operating station and is required for all modes. This should be set-up before proceeding.

1. Press **[Alt]-M**
2. Type the call sign of your station
3. Press **[Enter]**
4. Click: **OK**

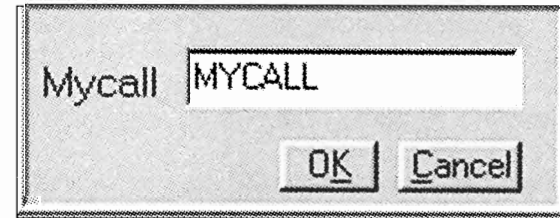

3.5 Main Screen

The main screen is composed of eight elements:

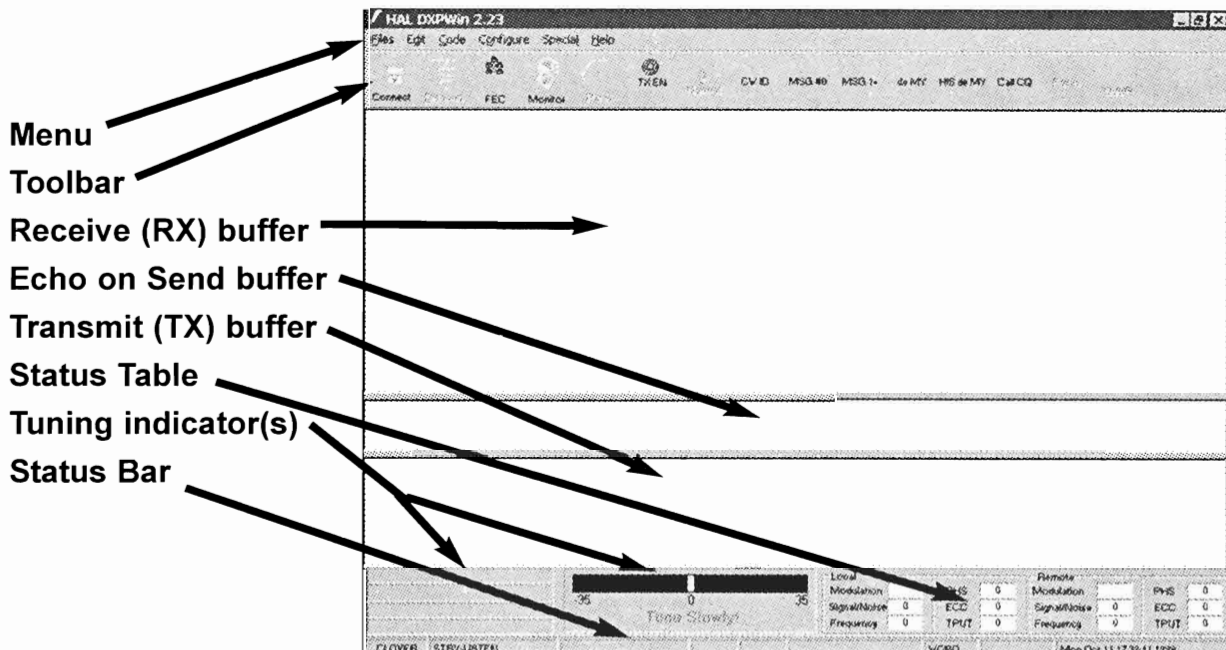

3.6 Menu line

The menu line provides easy access to the features and options of DXPWIn. Like many Windows based programs, the hotkey presses are depicted by the underscore character. For example: **[ALT]-F** chooses the file menu. Continue to hold **[ALT]** to choose submenus.

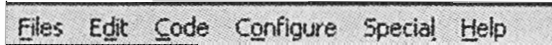

3.6.1 File Menu

Send text file : Text files may be sent in any mode. The data is sent exactly as it is stored in the disk file, without any modification to the End of Line sequence (EOL). Compression is not used in this mode.

Send Binary file: Use the "Binary" option to send all data files when using CLOVER-II. All 8 bits are sent in "binary mode" and all data is sent using PK-Ware compression. This mode may be used to send ANY file stored on your computer, including data, image, executable, and text files. This mode is actually a file-transfer mode and results in creation of this file at the other station. If a file of this name already exists at the other station, a duplicate file message is shown on the screen and the file transfer is cancelled. If you wish to transfer this file, rename it at the sending station or remove the previous filename from the receiving station.



Stop disk save/send: The stop send command closes the file immediately and no further information will be saved. Data that is contained in the DXPWIn TX buffer will continue to be sent until the buffer is empty. This may be a substantial amount of data when CLOVER-II is used. If an immediate stop send and stop transmit action is needed, use the "panic kill" **[ALT]-[F7]**.

Save RX to Disk: All received data may be saved to disk as a computer file. Data bytes or characters are saved exactly as received in the disk file, including End Of Line (EOL) sequence and errors that may have been caused by noise, poor typing, etc.

Save Statistics to Disk: Available only when in CLOVER mode. All channel statistics of a CLOVER link are stored in an ASCII data file that is compatible with most spread sheet programs. The file name is created automatically in the following format:

MMDDHHmm.TST (month/day/hours/start minute/.statistic extension)

The three user entry fields at the beginning of each statistics file are:

FREQ [] (6 characters maximum)
 NAME [] (16 characters maximum)
 OTHER [] (16 characters maximum)

The data fields are:

time = HHmmss (hr/min/sec)	rate = Throughput in bytes-per-sec (00-99)
my = MYCALL (8 char max)	snr = Signal-To-Noise Ratio (00-99 dB)
his = HISCALL (8 charmax)	frq = Frequency Offset (0-±30Hz)
mod = (BPSM, QPSM, 8PSM, 8P2A, 16P4A)	phs = Phase Dispersion (000-256)
bias = 1 (Robust), 2 (Normal), 3 (Fast)	ecc = Error Corrector (00-100; XX = exceeded)
	tpr = Not used

Load Firmware: The **Load Firmware** menu option allows the user to upload new **_.S28** and **_.LOD** files into the DXP38 flash memory without any hardware changes. While DXP38 modems are shipped with the latest versions of **_.S28** and **_.LOD**, upgrades may be obtained from the HAL website (www.halcomm.com) or by contacting customer service (see 1.2.2 Software and Documentation Update). Unless directed by customer service, always upload both files to the DXP38. The DXP38 now has current files uploaded to the flash memory.

Print RX Buffer: Sends the contents of the RX buffer to the printer. It is advisable to use the Print Setup option if printing to other than the Windows default printer.

Print Setup: Gives optional system printer settings. The user may choose to print to any of the installed printers on the system.

3.6.2 Edit Menu

The **Edit** menu allows for basic Windows text editing features. DXPWIn allows the user to cut and paste text from the TX or RX buffers onto and from the Windows clipboard. The standard windows hotkeys are used for operation.

3.6.3 Code Menu

The **Code** menu allows the user to easily switch between the different operating modes of the DXP38.

3.6.4 Configure Menu

The **Configuration** menu allows the user to open the configuration options and Save the Configuration. This menu is the most complex part of DXPWIn setup. Configuration includes all of the options for each of the modes, settings, and messages. To view the options available for each of the modes click the tab associated with that mode. Further explanation for these settings is found in sections 3.14 - 3.17 for each of the modes. General and Message configurations are explained in section 3.13. If you choose to make any changes now, be sure to save the configuration by clicking: **Save Configuration**

Save Configuration: This option updates the configuration file containing all of the user settable options. You may choose to save your configuration after setting up the various options in DXPWIn. This allows DXPWIn to begin with the chosen options in the configuration file.

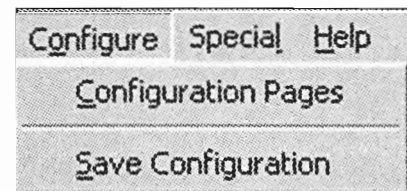
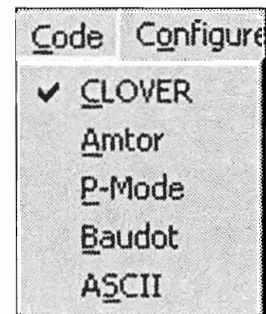
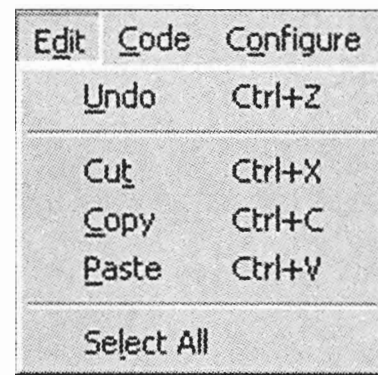
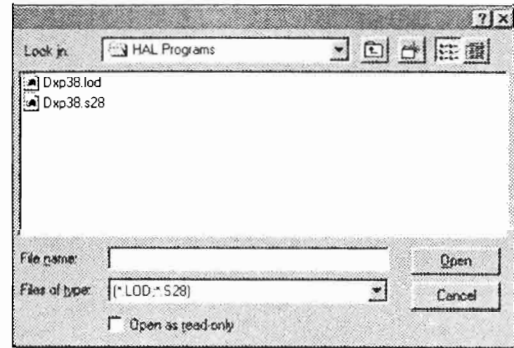

3.6.5 Special Menu

The **Special menu** allows the user to clear any of the three buffers as well as all three buffers at once.

The **Test** option tests the tones available to the current operating mode.

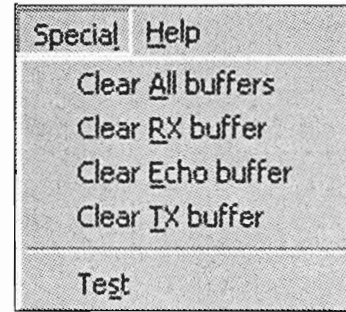

3.7 Toolbar

The toolbar provides quick and easy access to certain configuration settings. Each mode has its own toolbar with different "buttons" allowing changes to the corresponding configuration setting.

CLOVER

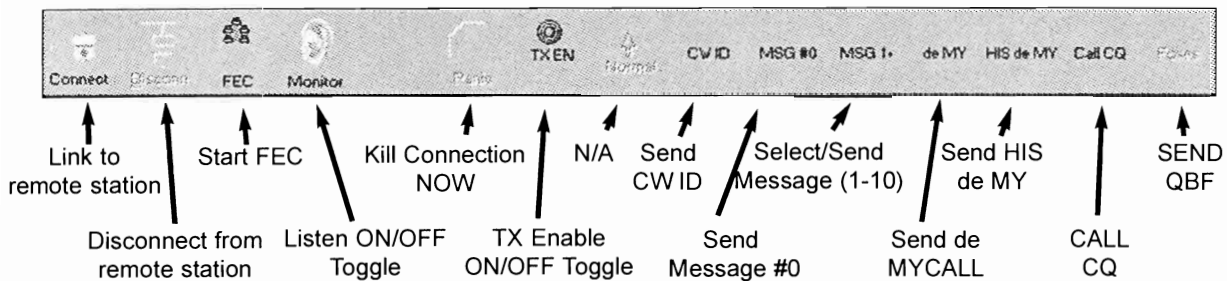

P-Mode

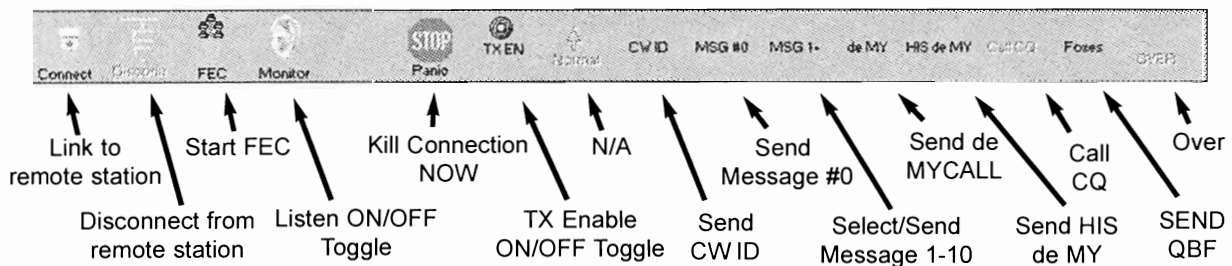

Amtor

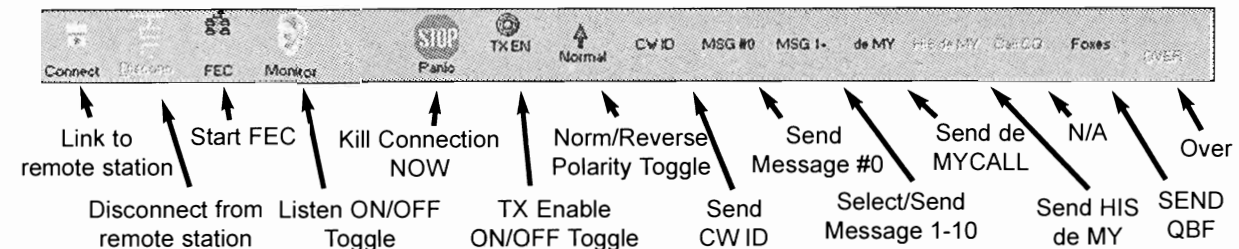

Baudot RTTY

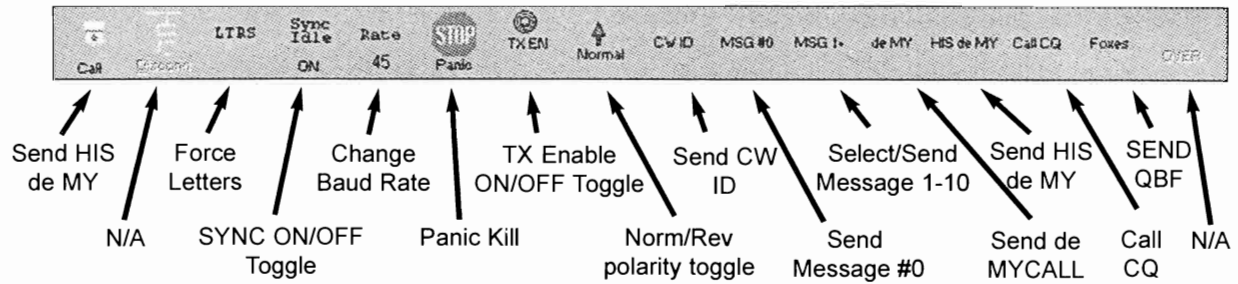

ASCII RTTY

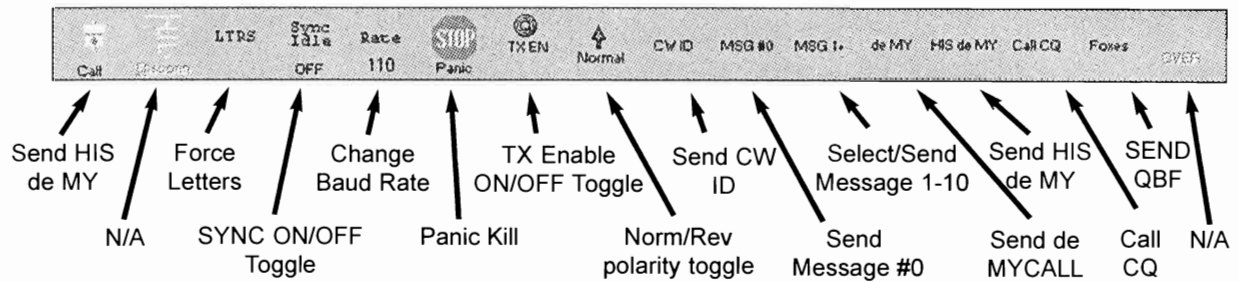

3.8 Receive (RX) Buffer

The upper half of the main screen shows the most recent lines of text received. Similar to the DOS based DXP38.EXE program you may choose to increase the size of the viewing area by hiding the tuning indicator(s) [ALT]-X.

3.9 Echo on Transmit (TX) buffer

The middle screen shows echo the echo on transmit buffer. This allows the user to view what has been sent by the DXP38.

3.10 Transmit buffer

The lower area of the screen shows data that is ready to be sent from the transmit (TX) buffer. The user may choose to hide the tuning indicator(s) to increase the viewing area [ALT]-A. To enter the TX buffer press [ALT]-X. Similar to the receive buffer, the buffer may be scrolled by pressing the [up arrow] or [down arrow]. The user may also click in the receive buffer, move the cursor, and highlight text. This allows the ability to cut [Ctrl]-X, copy [Ctrl]-C, paste [Ctrl]-V, and delete [Delete]. Press [ALT]-V to clear the TX buffer.

3.11 Tuning indicators

In addition to the front panel tuning display on the DXP38, DXPWin provides software tuning indicators that allow very accurate and rapid tuning of CLOVER, RTTY, AMTOR, and P-Mode signals. The tuning display may be easily viewed or hidden by pressing **[ALT]-X**. For CLOVER, tune for maximum and equal length for all four tones. In FSK modes (RTTY, AMTOR, and P-Mode), tune for maximum length of the Mark and Space signal amplitudes shown on the center two bars.

FSK modes also simultaneously show a frequency tuning display to adjust for minimum frequency error. CLOVER also has a similar display labeled Frequency Error. Switching between upper and lower sideband is made easy by clicking either **LSB** or **USB**.

CLOVER has an additional status table that displays measured signal parameters. This table is shown when either the tune or frequency error tuning displays are being viewed. The data columns show:

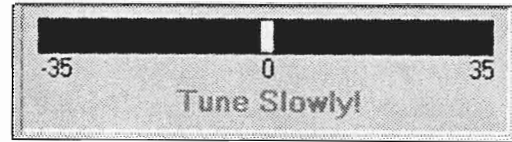
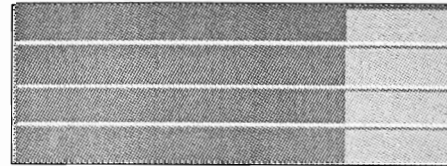

Local		PHS	0
Modulation		ECC	0
Signal/Noise	0	TPUT	0
Frequency	0		

Remote		PHS	0
Modulation		ECC	0
Signal/Noise	0	TPUT	0
Frequency	0		

- Modulation** = Modulation mode (BPSM through 16P4A)
- Signal/Noise** = Detects signal-to-noise ratio (dB)
- Frequency** = Tuning error (\pm 1 Hz increments)
- PHS** = Phase dispersion in log units (low numbers good)
- ECC** = Error correction capacity used (0 to 100% XX fail)
- TPUT** = Throughput

Notes:

1. You may not be able to precisely “zero” the Frequency Tuning Bar on the frequency of the sending station. This is not a problem. Some transceivers tune in 10 Hertz steps.
2. If you are the sending station you should avoid tuning at all after a link is made.
3. In CLOVER -II the CW ID is sent using tone “T2”.

3.12 Status Bar

The Status bar provides quick information about the operating mode, status, and time. When in doubt, look here first.



3.13 General Configuration

DXPWin provides quick access to the configuration options. To access these options choose **Configuration** from the **Configure** menu (section 3.6.4). Examples for the General and Message options are provided below. Descriptions on the options for each mode is described in sections 3.14 to 3.17. To apply the changes be sure to click **Save**.

General: These settings allow you to modify General Settings that apply to most modes of operation.

Special Features Include:

- Scan Control
- Audio Gain Control
- Printer Control
- Print Squelch Adjustment
- Font and Color Options

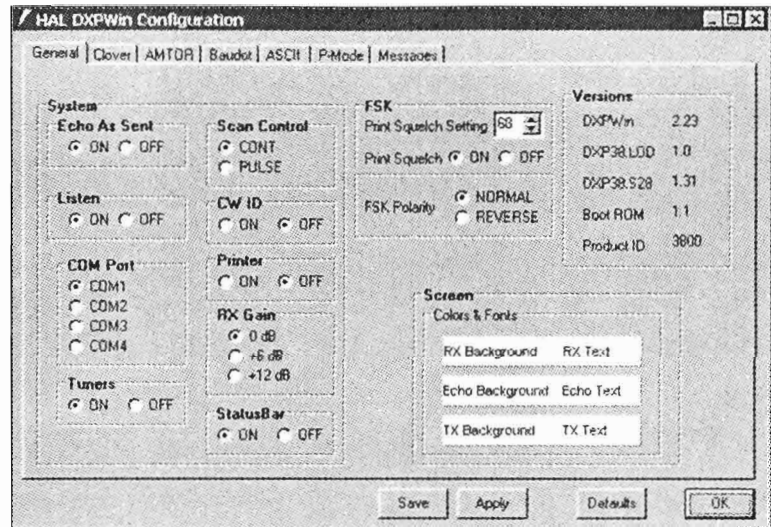

Messages: These settings allow you to program ten Here is messages, MyCall, MySelcall 476, MYselcall 625, Group Call, Hiscall List, and HisSelcall List. Be sure to click **Save** to save your changes.

Here is messages may be toggled through by clicking the up/down arrow buttons. Notice that you may also program WRU (Who Are You) from this menu screen. Choose Save when finished.

HisCall and HisSelcall provide pull down lists by clicking the down arrow. You may view the lists, add to the list, or delete an entry.

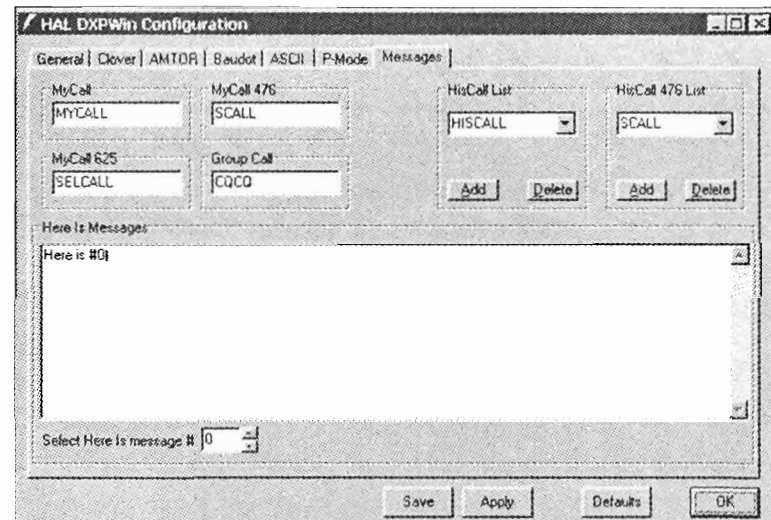

3.14 Operating RTTY

3.14.1 RTTY Codes

DXPWin includes two RTTY modes, 5-bit Baudot at data rates of 45, 50, 57 or 75 baud and 8-bit ASCII at 75 or 100 baud. Either "U.S. Military Baudot" or "CCITT No.2" Baudot character set may be selected in the configuration settings.

3.14.2 Starting RTTY

To start RTTY modes choose either Baudot or ASCII RTTY from the Code menu. This will change the screen and toolbar to match the available options of the mode you choose.

3.14.3 RTTY Data Rates

The baud and WPM equivalent for each code and speed is shown in Table 3.1

**Table 3.1
RTTY Data Rates and Speeds**

CODE	BAUD	WPM	COMMENTS
BAUDOT	45	60	"Standard" Baudot Speed
BAUDOT	50	65	"European" Baudot Speed
BAUDOT	57	75	"Weather" Baudot Speed
BAUDOT	75	100	Most Baudot "Mailboxes"
ASCII	75	67	Non-standard Speed
ASCII	110	100	"Standard" ASCII Speed

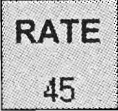
Click:  or use Hotkey [ALT]-R

3.14.4 Control options

These available CONTROL options are on the toolbar for quick and easy access.

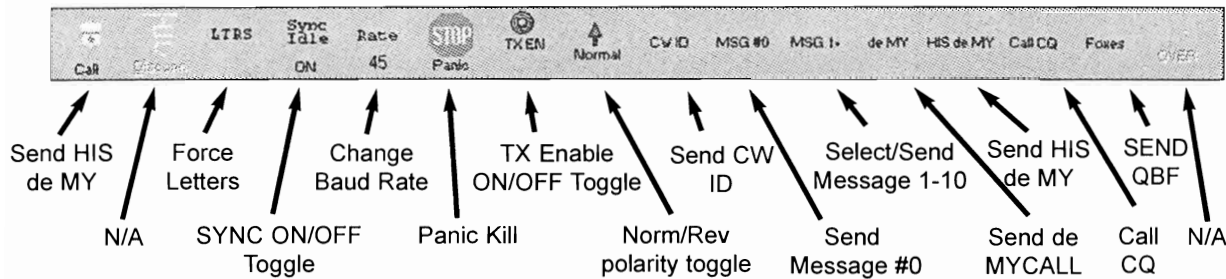

TX Enable ON/OFF Toggle: This option controls the state of the transmit buffer and the PTT transmit/receive control signal. In disabled state, the transmitter will not be turned ON and text typed into the transmit buffer will be held until this control is set to enabled. Disabled is the normal receive state. This control changes from disabled to enabled each time this option is selected.

The enabled condition actually has two states:

1. If you have pre-typed text into the transmit buffer and the state is changed from disabled to enabled, the transmitter is turned ON and text is sent at the chosen code and data rate. The transmitter will remain "on-the-air" and text will be sent, the PTT line will revert to receive and RTTY can be received.
2. If there is no text in the transmit buffer, the user may choose to actively receive while in the enabled state. However, this state will immediately send when the first character is entered in the transmit buffer. This method is analogous to "Full break in". In actual use, most operators prefer to always set this option to disabled except when it is their turn to transmit. This allows pre-typing your response while receiving the other station ("ASR" mode).

NORM/REV Polarity Toggle: This option controls the polarity of your RTTY signal. It sets the polarity of both the receive and transmit data sections of the DXP38. The default settings for RTTY and AMTOR are shown in Table 3.2.

**Table 3.2
Default Settings**

Polarity:	NORM (Mark = lower frequency tone)
TONES:	Mark = 2125 Hz; space = 2295 Hz Shift = 170 Hz; Center = 2210 Hz
Radio:	LSB mode

Baudot FORCE LTRS Key: In addition to the USOS

option, the **LTRS** button forces the receive terminal to LTRS case at any time. This is often the preferred method to actively watching print as it is received. The hotkey **[ALT]-G** may also be used.

SYNC: The Sync option is often called "Sync-IDLE" (or "diddle"). When ON, non-printing characters will be inserted into the transmit data stream if your typing has not been produced a word or character to be transmitted.

In Baudot RTTY, the "LTRS" (letters) character is sent; in ASCII, the "NULL" character is used. Both are "non-printing" characters and may help maintain synchronization of your RTTY signal at the other station.

3.14.5 Configuration Options

The Configuration page shows options available for both Baudot and ASCII RTTY. The configuration page is another way to view and set TX EN, NORM/REV polarity, SYNC IDLE, and USOS (only baudot) as well as other user settable options.

Other RTTY parameters include:

Baudot USOS (UN-Shift on Space): Baudot code uses its 5-bit code combination twice - once for letters and again for numbers and symbols. A special pair of Baudot characters set the receiving terminal to the correct "case" - Letters (LTRS) or Figures (FIGS). Noise can be interpreted as a FIGS Baudot character, setting the receiver printer or display to FIGS case by accident and garbles the data received after that point. If enabled, USOS will return the receive display or printer to LTRS case after the reception of a space character. While this is a very useful feature when receiving text, you may wish to turn USOS off when receiving strings of numbers, particularly if the sending station does not send new FIGS characters frequently (a frequent problem in military systems and when receiving weather sequence reports).

EOL: The End of Line (EOL) characters may be set for both Baudot and ASCII modes. The selected EOL sequence can include CR(Carriage Return), LF (Line Feed), and LTRS (Letters -Baudot only). The recommended standard EOL sequences are CR LF LTRS in Baudot and CR LF in ASCII. However, some Baudot operators prefer CR CR LF LTRS. Some computer programs prefer CR only as the ASCII EOL.

CODE No2/US: The DXP38 Baudot code may be set to use either the CCITT No. 2 5-unit code or the Military Interoperation Baudot Code. All letters and numbers are the same in both versions of the code.

The differences are:

Table 3.3
Baudot Code Differences

CODE	US Baudot	CCITT No. 2
FIGS-D	\$ (dollar sign)	\$ (dollar sign, not designated by CCITT)
FIGS-H	# (number sign)	# (number sign, not designated by CCITT)
FIGS-J	' (apostrophe)	BELL
FIGS-S	BELL	' (apostrophe)
FIGS-V	; (semi-colon)	= (equal sign)
FIGS-Z	" (quotation)	+ (plus sign)

PTT ON Delay: PTT ON Delay is a programmable delay that is used to compensate for the turn-on time of the transmitter. The number programmed is the delay in milliseconds (ms) between setting the PTT line to ground (transmit state) and the release of data to be transmitted. Use this delay to prevent the garbling of characters during the time that the transmitter relays are switching. The factory default is 20ms; PTT ON may be set between 01 and 99 ms.

PTT OFF: PTT OFF is a programmable delay that is used to compensate for the turn-off time of the trans-

mitter. The number programmed is the delay in milliseconds (ms) between sending the last transmit data byte and releasing the PTT line to open (receive state). This delay is often used to prevent TX/RX switching during short pauses when typing text. The factory default value is 20 ms; PTT ON may be set to a number between 01 and 99 ms.

FSK POLARITY: This option controls the FSK Transmit Output signal as discussed in section 2.2.4 of this manual. Please refer to Table 2.3 on page 2-5 for a full explanation of how to use this option.

FSK TONES: The FSK transmit and receive tone frequencies can be set to any frequency between 500 Hz and 3000Hz in 1.0 Hz increments. The frequencies can be specified as either Mark or Space tone frequencies, or the center and shift frequency. Separate sets of Mark/Space frequencies are provided for RTTY/AMTOR and P-Mode.

3.14.6 Special RTTY Transmit Keys

Special key combinations are provided to send special RTTY characters:

Table 3.4
Default Settings

KEY	CHARACTER	NOTES
[Ctrl]+G	Signal Bell	"Diamond" symbol on screen
<	LTRS	Only Baudot and TOR
>	FIGS	Only Baudot and TOR
[ALT]+Y	12 LTRS	Sequence of 12 LTRS

3.15 Operating CLOVER-II

This section describes the steps necessary to operate the DXP38 in the CLOVER-II mode. Unless you are already in CLOVER, you need to select the mode CLOVER from the Code menu. Always remember to Save Configuration upon exiting DXPWIn if you wish to save your settings.

3.15.1 Tuning A CLOVER Signal

There are five different tuning aids available, three displayed on the computer screen and two shown by the DXP38 front panel LED array. Use **[ALT]-X** to toggle between tuning displays.

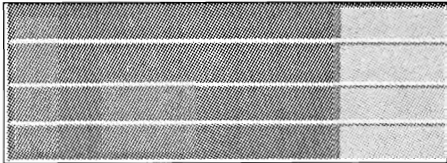
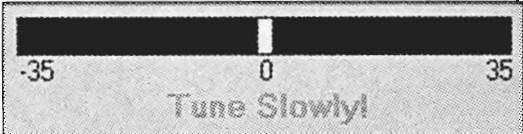
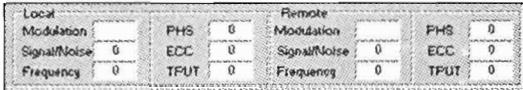
STEP	ACTION
1	Tune the transceiver until all four bars display equal magnitude. Stop when the bars "freeze" and the link message or FEC message appears
2	Press [Alt]+A to access the Frequency Error Tuning Bar
3	Make very small adjustments. It will take a moment for the change to be reflected. Repeat this step until you are close to the frequency of the sending station. STOP TUNING.

DXP-38 Front Panel Tuning Indicator

Crossed X Display: With the display switch in the "M/S" position, the DXP38 front panel "+" display shows the amplitude of each of the four CLOVER tone channels, one channel for each leg of the "+". Typical displays when tuning a CLOVER-II signal are shown in Figure 2.4 Page 2.10.

Δf Display: When the display switch is in the " Δf " position, the front panel LEDs operate much like the frequency error screen display except that the vertical axis of the "X" is used to emphasize fine-tuning. Typical displays in Δf mode are shown in Figure 2.5 page 2.10.

Note that CLOVER data can be updated only once per received data block - once every 2.8 seconds in CCB mode and as long as only once every 19.88 seconds in ARQ mode when receiving BPSM modulation. Tune slowly and carefully!

3.15.2 RX/TX Status Table

In ARQ mode, CLOVER-II dynamically adjusts its modulation to match the current propagation conditions. The receiving station measures signal parameters, determines the optimum mode, and sends mode change commands to the transmitting station. The measured parameters and transmit waveforms of the two stations are displayed in the numerical table in the upper right section of both tuning screens.

The data columns for each station show:

Modulation = Modulation mode (BPSM through 16P4A)
Signal/Noise = Detects signal-to-noise ratio (dB)
Frequency = Tuning error (± 1 Hz increments)
PHS = Phase dispersion in log units (low numbers good)
ECC = Error correction capacity used (0 to 100% XX fail)
TPUT = Throughput

This information can be extremely interesting and useful when analyzing propagation conditions. This data may be saved to disk for later analysis (see section 3.6.1).

NOTES:

1. You may not be able to precisely "zero" the Frequency Tuning Bar on the frequency of the sending station. This is not a problem. Some transceivers tune in 10 Hertz steps.
2. If you are the sending station you should avoid tuning at all after a link is made. The receiving station should use this procedure to refine the link frequency.
3. In CLOVER-II, the CWID is sent using tone "T2".

3.15.3 Adaptive ARQ Mode

The CLOVER-II Adaptive ARQ mode is a two station point-to-point communications mode using fully adaptive waveform control. The following steps show you how to initiate an ARQ LINK:

Step	Action
1	Press [F9] to begin an ARQ LINK or Click on the LINK Button.
2	Type the call sign of the other station in the HISCALL position and press enter or choose the call of your choice from the pull down menu.
3	An ARQ link will attempt to begin.

Note: Click on the **TX EN** button to toggle the transmit buffer ON/OFF.

ARQ LINK: During an ARQ LINK, data is transmitted in two ways. When both stations are "chatting" and the transmitted data from both sides is relatively short, the data is sent as part of each (CCB CLOVER Control Block). When the TX buffer of either station reaches a certain level of fill, Clover begins sending the information in a series of data blocks, followed by a CCB. Once the data in the TX buffer is sent, CLOVER returns to the CCB "chat" mode.

Data can be pre-programmed in the ten programmable messages, or as text files on a disk. You can use Load TX Buffer on the Files menu or press **[Alt]-L** to load a file from disk that does not exceed the 250 line capacity of the buffer. For files larger than the TX buffer, use the Send From Disk option of the Files menu. Files sent that way are transmitted directly, rather than through the TX buffer.

ARQ END Commands: There are two methods of ending a CLOVER-II ARQ Link

1. Pressing **[F7]** or clicking **DISC** on the toolbar breaks the link in the normal manner after all pending text has been sent. The link does not drop until the other station has confirmed receipt of the disconnect request.
2. Pressing **[Alt]-F7**, **[Ctrl]-F7**, or clicking **PANIC** produces similar action to **[F7]** except that all pending transmit data is abandoned and a disconnect request is issued immediately. Use this key combination only if you need to get off-the-air very quickly! Use of **PANIC** may force the other station to "retry out".

Initiating an ARQ CQ: To initiate an ARQ CQ call, press **[Alt]-F9**. The DXP38 will begin sending the CLOVER-II CQ sequence, a special version of the CCB ARQ format. The number of CQ calls is set with the "Fail Retries" parameter in the CLOVER configuration file. Other CLOVER stations on your frequency will see a message at the top left of their screen "ARQ CQ from (your call)".

Answering an ARQ CQ: To answer an ARQ CQ call, press **[Ctrl]-F9**. Your station will respond by linking to the calling station and you will see the other station's call at the top of your screen. If a CQ CCB is received, your transceiver is already tuned close enough in frequency to link. Use the Frequency Error Bar to fine tune after the link is established.

If a CCB fails to decode during the connect process, it will cause both stations to return to standby mode, regardless of the retry counters. Once a connection is established it will hold together very tenaciously.

Performance Hints For Keyboarders: If there are fewer than 256 characters pending, they will be sent using the "slow" CCB "Chat Mode". As soon as you exceed 255 pre-buffered transmit characters, CLOVER-II will "shift gears" and begin transmitting data in large data blocks using faster modulation forms. Block mode transmission will continue until all pending transmit text has been sent. When all available data has been sent, CLOVER will return to "Chat Mode". If you wish to immediately shift out of "Chat mode" to higher rate modes, preload the transmit buffer with at least 255 characters (about 3 1/2 lines) - a fully-loaded HERE IS message may be used for this purpose.

CLOVER-II is bi-directional. Both operators may type at the same time and data will be sent in both directions automatically without use of "OVER" commands. This feature works both in "Chat Mode" and in long-block ARQ data mode.

3.15.4 FEC Mode

While ARQ is the prevailing means of communications within CLOVER-II for passing traffic and general conversation, occasionally there is a need for a "one-station-to-many" broadcast. The FEC mode serves to provide just such a service. Any station tuned to the frequency of the FEC transmission will be able to monitor it. Errors are corrected at the receiving station, although it is not possible to request repeats. Also, FEC is not adaptive so you must make some judgement about current band conditions and select the modulation for your FEC transmission. The modulation you select can be changed during transmission.

Modulation modes: 2DPSM, BPSM, QPSM, 8PSM, 8P2A, 16P4A

In general, more robust modes for poor band conditions are the slower modulation rates (the first few in the above list).

ARQ features not available in FEC mode are:

- Repeat of blocks whose errors exceed the Reed-Solomon capacity
- Adaptive modulation control
- Chat, 1-way block or 2-way block modes

While all modulation modes may be used for FEC transmissions, it must be remembered that very good propagation conditions are required to support the high data rate modes. It is advisable to be "conservative" in the choice of transmission modes, particularly when FEC is used to send data to multiple stations. QPSM modulation generally works well under typical daytime conditions and provides throughput of 20 bytes per second (three times the AMTOR rate). If conditions are poor, use BPSM. 8PSM mode should be reserved for situations in which the propagation path is known to be stable.

CLOVER terminates the FEC transmission including your CW ID if it is enabled.

3.15.5 Listen Mode

Listen mode is a passive monitoring mode, similar to the Listen mode in AMTOR. It allows you to monitor any CLOVER activity that may be occurring.

3.15.6 Test Mode

The DXP38 Test mode provides two different selections of test tones: Single Tone Test and Four Tone Test. As discussed in Chapter 2, Test mode is used to set the transmit audio level. Follow the procedures of section 2.3 any time you alter the set-up of your transceiver to verify that the audio output levels are correctly set. DXPWin provides access to the two sets of test tones under the Special menu or you may choose to run the DOS based DXP38.EXE program to test the tones.

3.15.7 CLOVER-II Configuration Menu Parameters

The CLOVER Configuration menu includes options that are used to view and program CLOVER-II parameters. Most of these parameters may also be set via front screen menus and/or "hot-keys". However, general practice is to set-up the power-on default values in the configuration and save the configuration.

FEC Menu: The CLOVER-II FEC mode parameters are:

- Modulation: 2DPSM, BPSM, QPSM, 8PSM, 8P2A, 16P4A
- Code Effic: 60% (Robust), 75% (Normal), 90% (Fast)
- Block Size: 51, 85, or 255 bytes (coupled to modulation selection)

ADAPTIVE ARQ Menu: The following ARQ parameters are:

- Auto Bias: Robust (60% RS), Normal (75% RS), Fast (90% RS)
- Connect Retry: Number of connection retries before the link fails (00 - 99)
- Fail Retry: Number of block retry failures before link fails (00 - 99)
- Chat Count: CCB cycles before ARQ changes from CCB to long block mode (0-9)

LISTEN Menu: LISTEN mode may be either turned ON or OFF via the Configuration menu. The action is identical to use of clicking the **MON** button on the toolbar.

3.16 Operating AMTOR

AMTOR is an error-correcting communication mode, also known as "TOR", "SITOR" or CCIR-476 and CCIR-625. TOR actually has four sub-modes that may be chosen: (1) ARQ ("Mode A"), (2) FEC ("Mode B"), (3) LISTEN ("Mode L"), and (4) STBY (Standby).

AMTOR ARQ data is sent in pulses and both stations transmit in a time-sequenced order. Each station automatically requests a repeat if an error is detected. In FEC (broadcast), each character is sent twice (with a time separation). LISTEN is a receive-only mode that may be used to listen to ARQ or FEC signals. LISTEN mode cannot correct errors in received ARQ mode signals. STBY mode is the normal "rest" condition of an AMTOR station when monitoring a frequency. When your SEL-CAL code is received, the modem automatically switches from STBY to ARQ mode and responds. FEC reception is also automatic from STBY mode.

3.16.1 Control Options

These available CONTROL options are on the toolbar for quick and easy access.

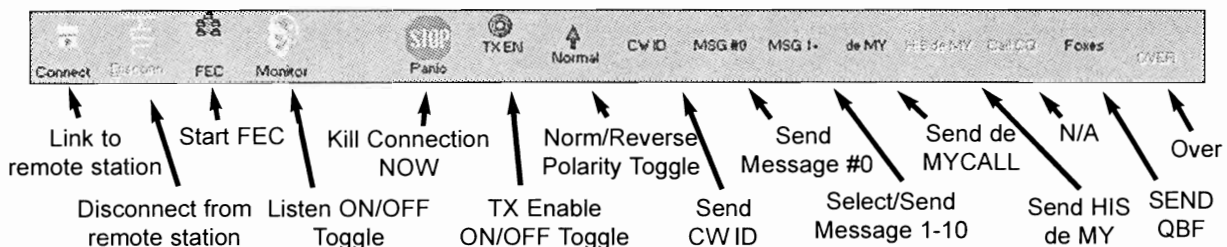

3.16.2 ARQ Mode

AMTOR ARQ mode may also be called "Mode A". The letters "ARQ" stand for Automatic Repeat ReQuest (or Query). ARQ is an error-detection mode in which one station sends a group of three characters and the other station may either acknowledge correct reception or request a repeat transmission. This is similar to CLOVER-II ARQ mode except that AMTOR cannot correct errors without repeat transmission and the AMTOR code itself is not completely "infallable" - AMTOR can print errors. The transmitters of both AMTOR ARQ stations are pulsed ON and OFF every 450 ms. ARQ mode requires use of transmitters and receivers that can rapidly switch between receive and transmit. Use of radio equipment with TX/RX switching times less than 20 ms is highly recommended.

The ARQ Link:

Start an ARQ LINK by pressing **[F9]** or use the toolbar LINK button. The ARQ menu will appear. Type a new SEL-CAL code or choose one of the CALL Directory choices.

Once a link has been successfully completed, the two ARQ stations will be synchronized and you may send text to the other station. However, no text will be passed until the link has been completed. Your transmitter should now be pulsing ON and OFF ("chirping").

Once the link has been established, the "Calling" label on the Status Bar will change to "Linked With XXXX". If your receiver speaker is turned ON, you will also hear the other station's short "chirp" response (control signals).

If you do not get a response from the other station, the TIME OUT option controls whether your transmitter continues "chirping forever" (TO = OFF) or the ARQ call automatically "times-out" (TO = 32 or 128). The TIME OUT (TO) option is normally set to "32" but may be changed on Configuration menu. A "quick-kill" or "panic-stop" may be done at any time by clicking **PANIC** or by pressing **[Ctrl]-F7**.

The DXPWn transmit text buffer may be used pre-type your transmit text. Transmitted characters are "echoed" in the echo as sent window. You can always gauge the progress of the ARQ transmitted output by looking at this window. If your typing is not as fast as the transmitted rate, AMTOR "idle" characters are automatically inserted (indicated by "IDL" instead of "TFC" on the center status line).

ARQ OVER Commands: If you are the current ISS (Information Sending Station), all you need to do to let the other station talk is click **OVER** on the toolbar. Likewise, he can return sending control to you by doing an over command.

If you are the IRS, the **OVER** button on the toolbar works as a **FORCED OVER** forcing a reverse of the channel. A **FORCED OVER** operates immediately and therefore interrupts whatever the other station is sending. Use it with care!

Even when a **FORCED OVER** is used, any unsent text is preserved in the transmit buffer. This text will be held and sent ahead of any additional pretyped text when your station is again the ISS.

ARQ END Commands: There are two methods of ending a AMTOR ARQ Link

1. Pressing **[F7]** or clicking **DISC** on the toolbar breaks the link in the normal manner after all pending text has been sent. The link does not drop until the other station has confirmed the disconnect request.

2. Pressing **[Alt]-F7**, **[Ctrl]-F7**, or clicking **PANIC** produces similar action to **[F7]** except that all pending transmit data is abandoned and a disconnect request is issued immediately. Use this key combination only if you need to get off-the-air very quickly!

ARQ WRU Feature: The AMTOR WRU (**Who aRe yoU**) feature allows the other station to confirm the identity of your station. Some Email programs use WRU when the first connection is made to the mailbox system. A special character is sent by the mailbox station that causes the DXP38 to respond with the ANSWERBACK message (a special type of "HERE IS" message).

The WRU feature may be turned ON or OFF, using the CONFIGURATION and TOR menus. The ANSWERBACK message is stored in HERE IS 9.

Assuming that WRU is turned ON and an ANSWERBACK message is programmed, the full operation sequence for WRU is as follows:

1. Station one is ARQ ISS and sends "\$" (dollar sign; FIGS-D)
2. The DXP38 at station two forces an OVER to become the ISS
3. Station two sends the ANSWERBACK text (HERE IS 9)
4. Station two sends a normal OVER, restoring the original ISS/IRS configuration

ARQ Mode Parameters: Several operating parameters for ARQ mode may be set via the configuration settings. These parameters have the following meaning:

WRU:	Enable or disable WRU mode.	Default = OFF
TIME OUT:	Turn time-out ON or OFF. When ON, an ARQ call to another station will cease after 1 minute of unsuccessful calls.	Default = ON
TD:	Transmitter turn on delay; the delay from setting the Push-To-Talk (PTT) line to transmit (TX) state and the start of the AFSK tones. Data modulation of the tones starts 5 ms after PTT is set to TX	Adj: 5-99 ms Default = 10 ms

CD:	Control delay between the end of a received block and the start of the first IRS transmission.	Adj: 10 - 99 ms. Default = 50ms.
MY 476 SCAL:	Selective call (SEL-CAL) characters for my station in CCIR-476 format.	
MY 625 SCAL:	Selective call (SEL-CAL) characters for my station in CCIR-625 format.	

3.16.3 FEC Mode

AMTOR FEC mode is also called "Mode B" and/or "Collective Broadcast Mode". FEC uses the same 7-bit character code as ARQ mode but sends each character twice, separated by the time it takes to send four other characters (called a "4-character interleave"). If the first received character is in error, the FEC mode receiving equipment examines the second character.

Starting FEC Mode: To start FEC mode, click **FEC** on the toolbar. FEC mode does not require a SEL-CAL code and may be used much like RTTY.

FEC Return to STBY Mode: In some cases, it is desirable for the DXP38 to return to AMTOR-STBY mode rather than to FEC-only receive mode. In this case, insert ZZZZ at the end of the transmitted text. The **[F7]** key may be used to insert the ZZZZ sequence.

FEC may also use the "panic kill" hot-key -- **[Ctrl]-F7**. In this case, pressing **[Ctrl]-[F7]** causes an immediate end to an FEC transmission and returns the DXP38 to AMTOR STBY mode (not to FEC). Use **[Ctrl]-F7** with restraint!

3.16.4 LISTEN Mode

The DXP38 includes a receive-only mode to monitor all AMTOR signals. The LISTEN mode (also called "MONITOR") automatically selects the AMTOR mode and decodes characters from ARQ or FEC received signals. To start LISTEN mode, click **MON** on the toolbar. When in AMTOR Listen, the DXP38 will also respond to P-Mode link requests.

3.17 Operating P-Mode

P-Mode is the HAL designation for a communications protocol that may also be known as "Pactor", a registered trademark of the Spezielle Communications System GmbH (SCS) firm in Hanau, Germany. P-Mode has four sub-modes that may be chosen: (1) ARQ, (2) FEC (UNPROTO), (3) LISTEN, and (4) STBY (Standby).

3.17.1 Control Options

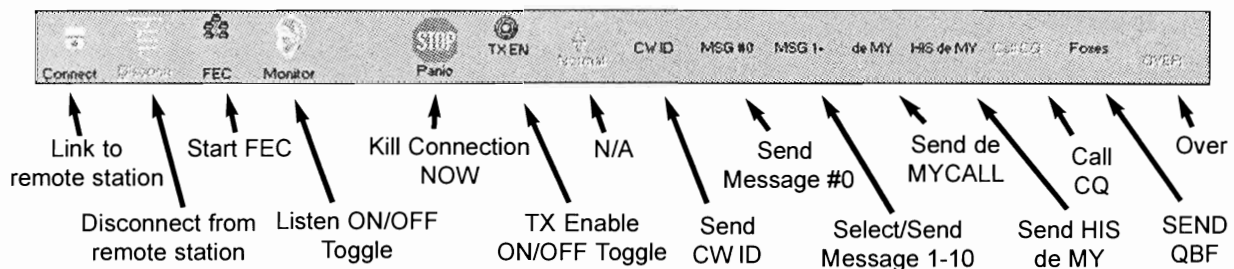

3.17.2 ARQ Mode

ARQ LINK: To Start an ARQ LINK press **[F9]** or click the LINK button on the toolbar. The Code menu will appear. Type the other stations call sign and Click **OK**. The P-Mode calling sequence will begin.

P-Mode Call Signs: Unlike AMTOR, but like CLOVER, P-Mode does not require a special selective call sequence of letters. Rather, the call sign of each station is used directly. Therefore, no special steps need be taken to program a "SEL-CALL" sequence.

Once the link has been established, the "Calling" label will change to "Linked With XXXX". If you do not get a response from the other station, the MAX ERROR option controls whether your transmitter continues "chirping forever" (MAX ERROR = 255) or the ARQ call automatically "times-out" (MAX ERROR = 30, the minimum). The MAX ERROR option is normally set to "80", but may be changed in CONFIGURATION. You may do a "quick-kill" or "panic-kill" at any time by typing the **[Ctrl]-F7** keys.

ARQ OVER Commands: If you are the current ISS (Information Sending Station), all you need to do to let the other station talk is click **OVER** on the toolbar. Likewise, he can return sending control to you by doing an over command.

If you are the IRS, the **OVER** button on the toolbar works as a **FORCED OVER** forcing a reverse of the channel. A **FORCED OVER** operates immediately and therefore interrupts whatever the other station is sending. Use it with care!

Even when a **FORCED OVER** is used, any unsent text is preserved in the transmit buffer. This text will be held and sent ahead of any additional pretyped text when your station is again the ISS.

ARQ END Commands: There are two methods of ending a P-Mode ARQ Link

1. Pressing **[F7]** or clicking **DISC** on the toolbar breaks the link in the normal manner after all pending text has been sent. The link does not drop until the other station has confirmed the disconnect request.
2. Pressing **[Alt]-F7**, **[Ctrl]-F7**, or clicking **PANIC** on the toolbar produces similar action to **[F7]** except that all pending transmit data is abandoned and a disconnect request is issued immediately. Use this key combination only if you need to get off-the-air very quickly!

ARQ P-Mode Parameters: Several operating parameters for ARQ mode may be set in the configuration menu. ARQ mode parameters have the following meaning:

CS DELAY:	Delay between the end of a received block and the start of the first IRS control data bit.	Adj: 10-50 Default=30
MAX DOWN:	In ARQ mode, the maximum number of flawed data blocks before reducing the data rate from 200 baud to 100 baud.	Adj: 2-30 Default=6
MAX UP:	In ARQ mode, the number of error-free blocks before increasing the data rate from 100 baud to 200 baud.	Adj: 2-30 Default=3
MAX TRY:	In ARQ mode, the maximum number of attempts to increase the data rate from 100 to 200 baud.	Adj: 0- 9 Default=2.
MAX ERROR:	In ARQ mode, the maximum number of retries when calling to link or maximum repeats to correct errors during a link.	Adj: 30-255 Default=80

MAX ARQ SUM:	In ARQ mode, the maximum number of the memory-ARQ counter. Memory-ARQ summation is cleared when MAX ARQ SUM is exceeded.	Adj: 5-60 Default=10
HUFFMAN:	In ARQ and UNPROTO/FEC modes, enable or disable Huffman data compression coding.	Default=ON.

3.17.3 FEC Mode (UNPROTO)

P-Mode UNPROTO (FEC) uses Forward Error Correction. FEC uses the same character code as P-Mode ARQ but sends each character 2 to 5 times, separated in time. If the first received character is in error, the FEC receiving equipment examines the 2nd, 3rd, etc. character.

FEC Data Rates: P-Mode FEC (UNPROTO) transmissions may use either a data rate of 100 or 200 baud. The rate is selected at the beginning of a transmission. Unless the communications path is extremely stable, 100 baud is recommended.

Starting FEC Mode: To start FEC mode, access the COMMAND menu and select FEC. FEC does not require a call sign code.

FEC Send/Receive Control: The FEC code actually sends P-Mode frames without an ACK/NAK response. There is no special startup as with AMTOR. Once FEC mode is started you must use **[F7]** to return to receive except as stated below.

FEC Return to STBY Mode: In some cases, it is desirable for the DXP38 to return to P-Mode STBY rather than to FEC-only receive. In this case click **DISC** on the toolbar.

FEC also includes a "panic kill" hot-key -- click **PANIC** on the toolbar or press **[Ctrl]-F7**. Pressing **[Ctrl]-F7** causes an immediate end of the FEC transmission, and returns the DXP38 to STBY mode (not to FEC). Use **[Ctrl]-F7** with restraint!

FEC Configuration Parameters: Two parameters apply to FEC mode:

FEC REPEATS:	The number of times each character to be transmitted is repeated.	Adj: 2-5 Default=2
HUFFMAN:	In ARQ and UNPROTO/FEC modes, enable or disable Huffman data compression coding.	Default=ON.

3.17.4 LISTEN Mode

The DXP38 includes a receive-only mode used to monitor P-Mode transmissions. The LISTEN mode (also called "**MONITOR**") will automatically select the mode and decode characters from ARQ or FEC (UNPROTO) received signals. In LISTEN mode, the DXP38 responds only to P-Mode link requests. However, the DXP38 will also respond to AMTOR link requests when in P-Mode STBY mode. Toggle the Listen Mode ON/OFF by clicking **MON** on the toolbar.

Chapter 4

Operation Under DOS

This Chapter provides a detailed discussion of how to use DXP38.EXE, the DOS-based terminal software provided with each DXP38 modem. This software is designed to be used in an "IBM™-compatible" personal computer running "PC-DOS V3.0" and later. DXP38.EXE may also be run as a DOS application in Microsoft™ WINDOWS, but performance may be slow or unpredictable when other applications are also running. DXP38.EXE provides convenient access to all standard features and modes of the DXP38 modem. However, many other terminal and control programs have been written for use with the DXP38 modem and you should consult their manual. Even if you choose to run other terminal software, you may wish to have DXP38.EXE available to use to check for correct operation of the DXP38 modem hardware itself.

This chapter has been designed to get you up and running quickly, yet provide detailed information that is easy to find when needed. Before you read this chapter, be sure to read Chapter 2 of this manual (Installation and Set-Up). If you have problems, please consult Chapter 5 (In Case of Difficulty).

4.1 Installing DXP38 software

After connecting the DXP38 and double checking all of your connections, it is now time to load the software.

Some PC users find it convenient to use "DOS SHELL" programs. These are utility programs in which you may list the programs you frequently use, select them from an on-screen menu, and run that program without having to use DOS commands to change directories, load programs, etc. A DOS Shell may in fact make it even simpler to run the DXP38. However, a "DOS Shell" may also automatically load other programs that interfere with some features of the DXP38. There are many varieties of "DOS Shell" programs available, some good, and some "not so good". Try running the DXP38 without the DOS Shell first and make sure it works properly. If it does, then try using your DOS Shell. If problems develop, change your DOS Shell program or run DXP38 without using the Shell program.

Windows uses a version of a "DOS Shell" when running DOS based applications. Although DXP38.EXE is designed to work inside this type of DOS shell. Windows users are recommended to exit to DOS before installing or running DXP38.EXE for the first time.

Some PC users also make use of memory resident utility programs (also called "TSR" programs). Typical uses of such programs may be to scroll the CRT screen, check spelling, or redirect video for an application program. A resident program is typically loaded as part of the AUTOEXEC.BAT program and stays resident in RAM thereafter. It may or may not work properly with the DXP38. It may use memory space that is required by DXP38.EXE. The software will not run if the PC cannot allocate sufficient memory. It is impossible to predict whether or not a given memory resident program will or will not work with DXP38. HAL suggests that you first try the DXP38 with all resident programs removed and then try adding each resident program one-by-one to test for compatibility. HAL cannot guarantee operation with any resident programs.

Use the following steps to install or upgrade DXP38.EXE:

STEP	ACTION
1	Boot Your PC (Turn the power on). Windows users exit to DOS.
2	Put your DXP38.EXE diskette in floppy drive A:
3	Type A: INSTALL [ENTER] .
4	A directory named DXP38 will be created on your hard disk and all DXP38 files will be loaded into the directory. (Upgrades will over-write previous installations).
5	Change to DXP38 directory by typing C:\DXP38 [ENTER] .
6	Run DXP38 by typing DXP38 [ENTER] or DXP38/COM2 [ENTER] for COM2

NOTE: Users updating to current versions of DXP38.EXE should also update DXP38.S28 and DXP38.LOD files. Section 4.7.6 describes the steps required to update these files. New users do not need to install these files. Current versions are installed prior to shipment.

4.2 Manual Conventions

When DXP38.EXE software is run on your PC, the following manual conventions will be used to describe which keys should be used:

1. All user-entered keystrokes are in **BOLD** print.
2. If a letter is to be typed as a command, it may be either lower case or UPPER CASE.
3. Multi-letter keytop labels are shown in [BRACKETS]. For example:

[Enter], [F1], [F8], [Ctrl], [Alt], [Shift], [Home], [PgUp], etc.
Each [BRACKETED] set represents one key to be pressed.

4. Some keys must be held down while pressing a second key. These will be shown with a dash (-) between key presses.

For example: **[Alt]-C** This notation should be interpreted as:
press and hold the **[Alt]** key
press and release the **C** key
release the **[Alt]** key

5. Separate sequential command entries are separated by commas.

For example: **[F1], M** implies:
press and release the **[F1]** key
press and release the **M** key.

DXP38 commands are entered in one of three ways:

1. Type **[F1]** to show the command menus. Use **[arrow keys]**, **[Enter]**, and **[Space bar]** to choose options; type **[Esc]** to back up one menu step.

2. Type "Hot-keys": **[Alt]-Q**, **[Shift]-[F6]**, for example.
3. An "expert user" may use single-letter command abbreviations once **[F1]** is typed to enter command mode. For example, **[F1]** then **M** enters command mode and selects the **Mode** menu window. The appropriate "expert" keys associated with each command are shown in the command windows as highlighted characters. The "expert user" may speed type the entire command sequence without waiting for each command menu to be displayed.

4.3 MYCALL Setup

MYCALL is used for all modes and should set-up before proceeding farther.

1. Press **[Alt]-M**.
2. Type in the call sign of *your station*.
3. Press **[Enter]**.
4. Be sure to save the configuration upon exiting the program.

4.4 Main Screen

The main screen is composed of seven distinct elements:

- Tuning Indicators
- RX/TX Status Table
- Receive (RX) Buffer
- Status Line
- Command Line
- Transmit (TX) Buffer
- Information Line

Example:

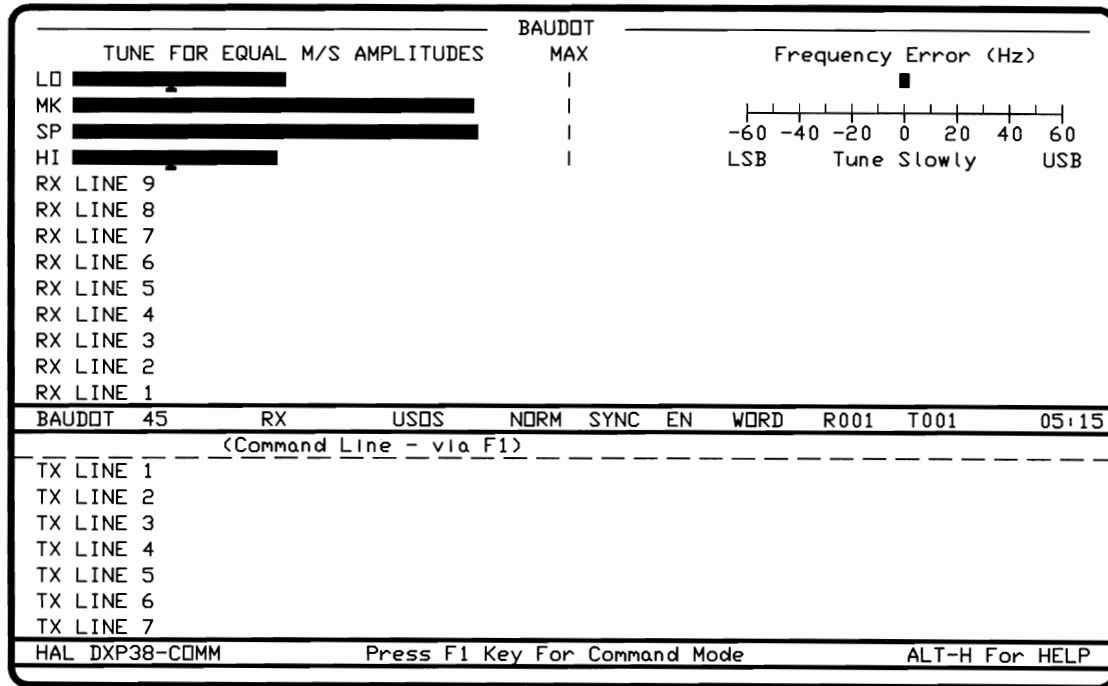

Figure 4.1 DXP38.EXE Main Screen

4.4.1 Tuning Indicators

In addition to the front panel DXP38 tuning indicators, the screen includes tuning display features that may be used to achieve very accurate and rapid tuning of CLOVER, RTTY, AMTOR, and P-Mode signals. Type **[Alt]-A** to turn the tuning bar display *ON*. In CLOVER, tune for maximum and equal horizontal bar length for all four tones. In FSK modes (RTTY, AMTOR, and P-Mode), tune for maximum length of the center two bars (signal amplitude in the Mark and Space channels). The top and bottom bars show response above and below the correct frequency channels.

Press **[Alt]-A** again to access the frequency tuning bar and adjust for minimum frequency error. Then *let go of the knob*. The frequency tuning display works the same in CLOVER and in FSK modes. The tuning bars are easy to read, but may take some practice. **Remember that if you tweak the knob, CLOVER must start over with its frequency/phase integration and either data may be lost (FEC mode) or extra repeats may be required (ARQ mode).**

4.4.2 Receive (RX) Buffer

The upper half of the screen shows the most recent lines of text received, up to a maximum of 14 lines. However, when the tuning bars and RX/TX status table are displayed, only the most recent 9 lines of RX text are shown. The receive buffer will hold up to 250 lines. All lines may be viewed by typing **[ALT]-R** to select the RX buffer and then **[up arrow]** or **[down arrow]** scroll the display. The RX buffer can be cleared with **[Alt]-U**.

4.4.3 Status Line

The Status Line indicates the current status of several of the DXP38 parameters. Figure 4.2 through 4.7 show the arrangement and status indications for each mode of operation.

4.4.4 Command Line

This line shows the various options of the main menu. The entire menu shows only if you press **[F1]** (see Figures 4.2 through 4.7).

The main menu options are as follows:

Code, Mode, Control, Messages, Files, and Exit.

4.4.5 Transmit (TX) Buffer

The lower area of the screen shows data that is ready to be sent from the transmit (TX) buffer. The TX Buffer screen area consists of 2 to 11 lines between the Code status line and the Information line at the bottom of the screen. The buffer is scrollable and will hold up to 250 lines. **[Alt]-X** selects the TX buffer for scrolling. The **[up arrow]** and **[down arrow]** as well as **[PgUp]** and **[PgDn]** scroll the display. The TX buffer can be cleared with **[Alt]-V**.

4.4.6 Information Line

The last line of the screen is the information line, a "mini-Help" line. Commands and control key functions are listed here for the various menus. When in doubt about, look here first!

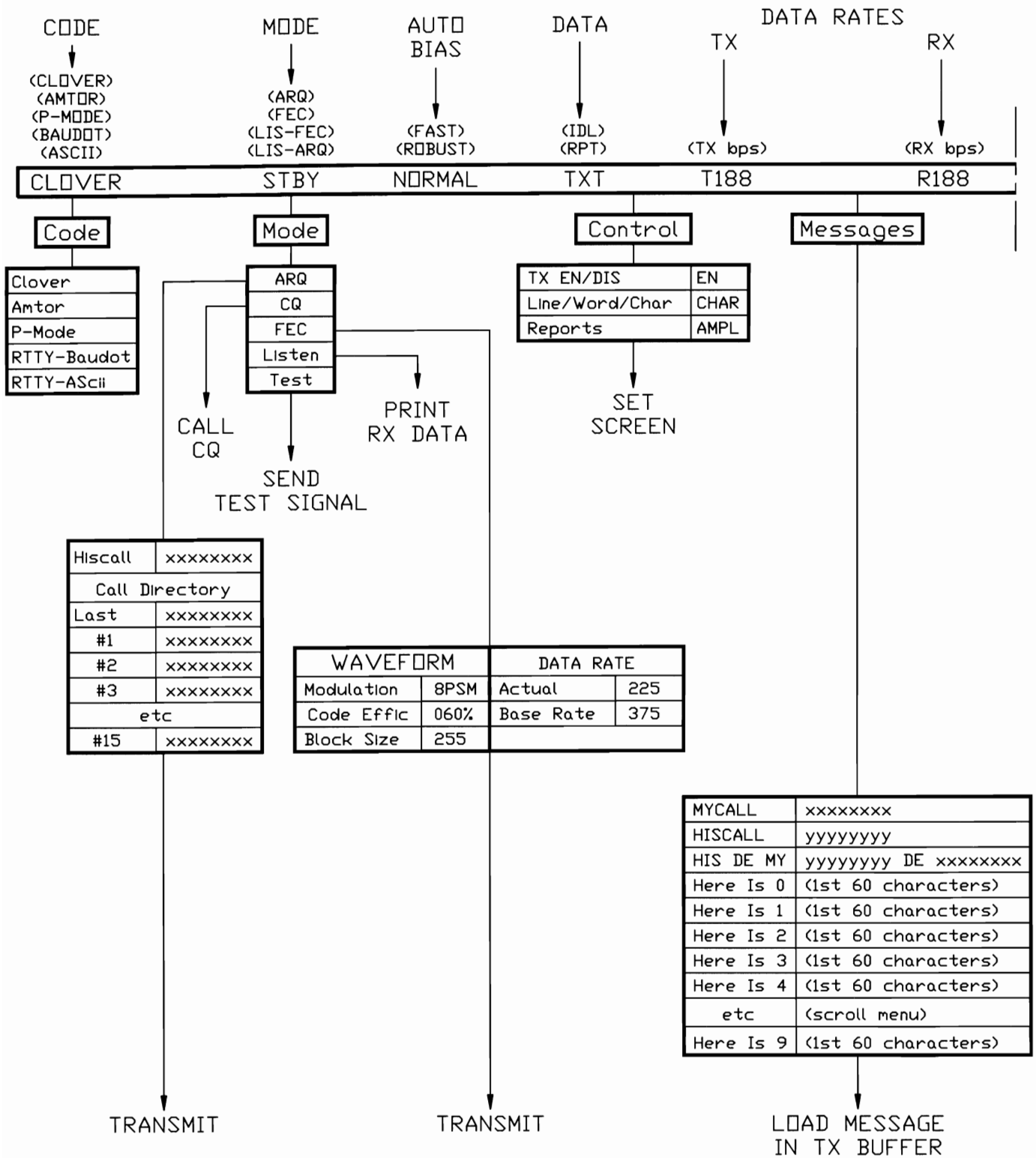

Figure 4.2 Main Menu Tree for CLOVER (left side)

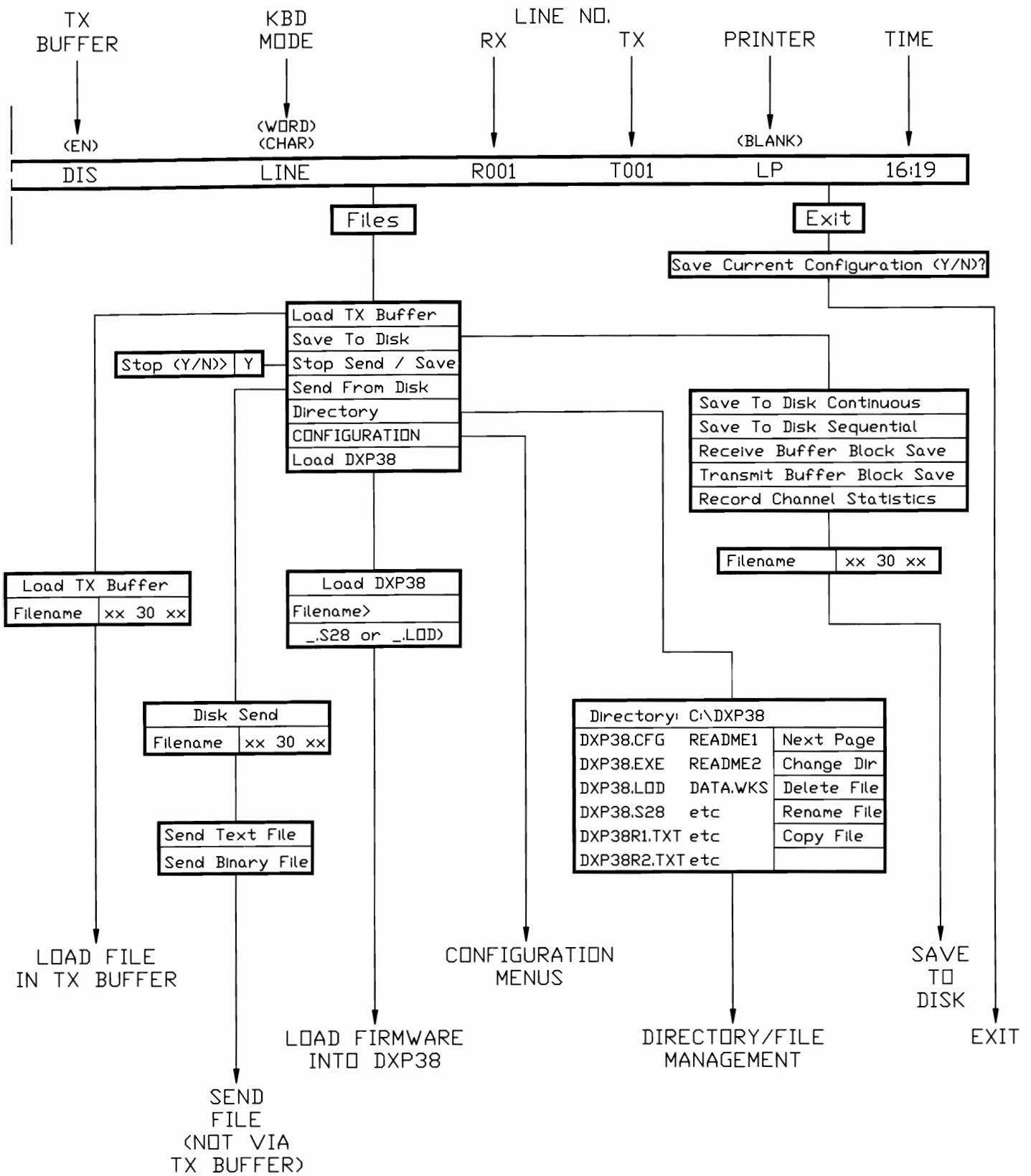

Figure 4.3 Main Menu Tree for ALL Codes (right side)

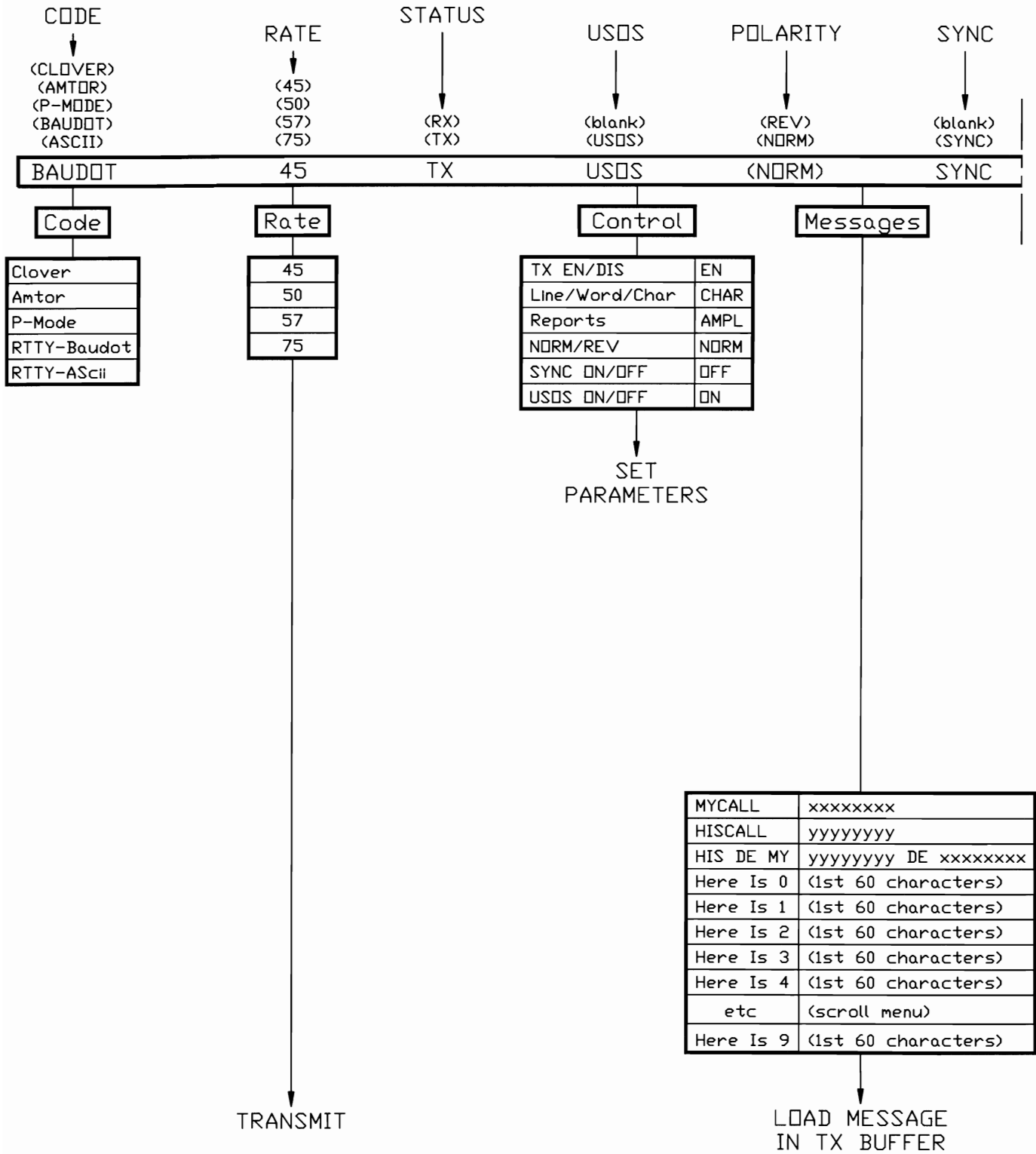

Figure 4.4 Main Menu Tree for Baudot RTTY (left side)

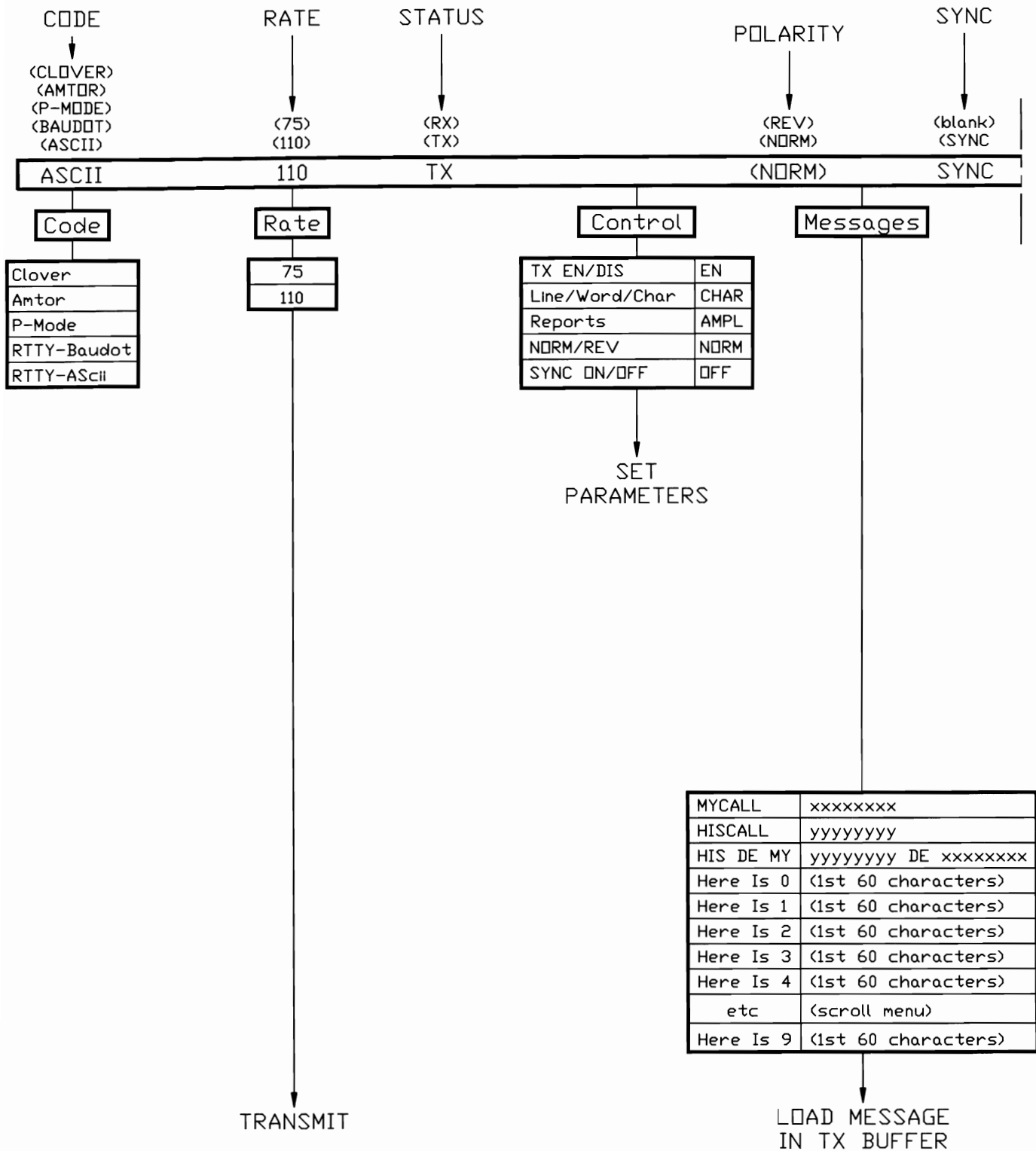

Figure 4.5 Main Menu Tree for ASCII RTTY (left side)

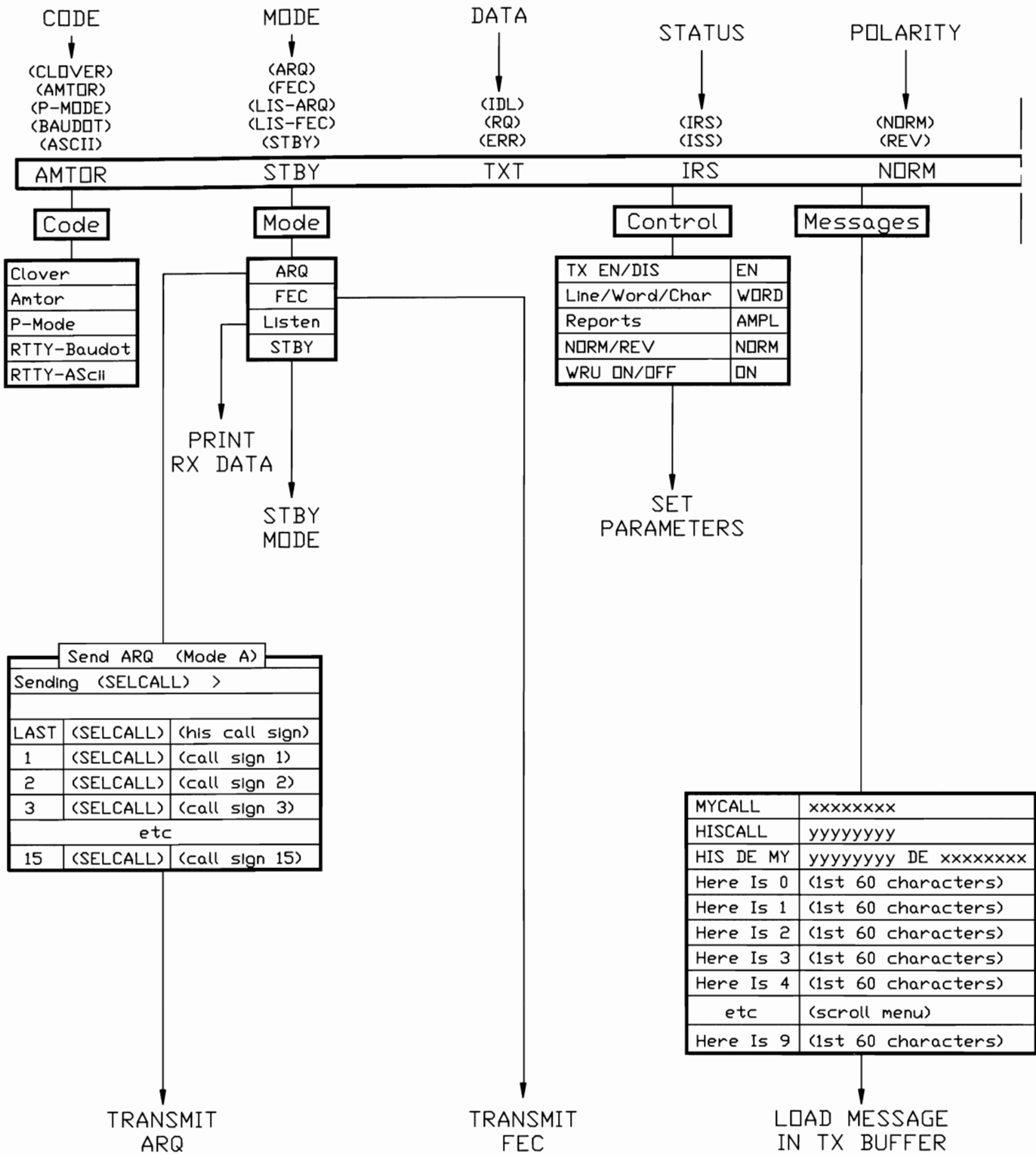

Figure 4.6 Main menu Tree for AMTOR (left side)

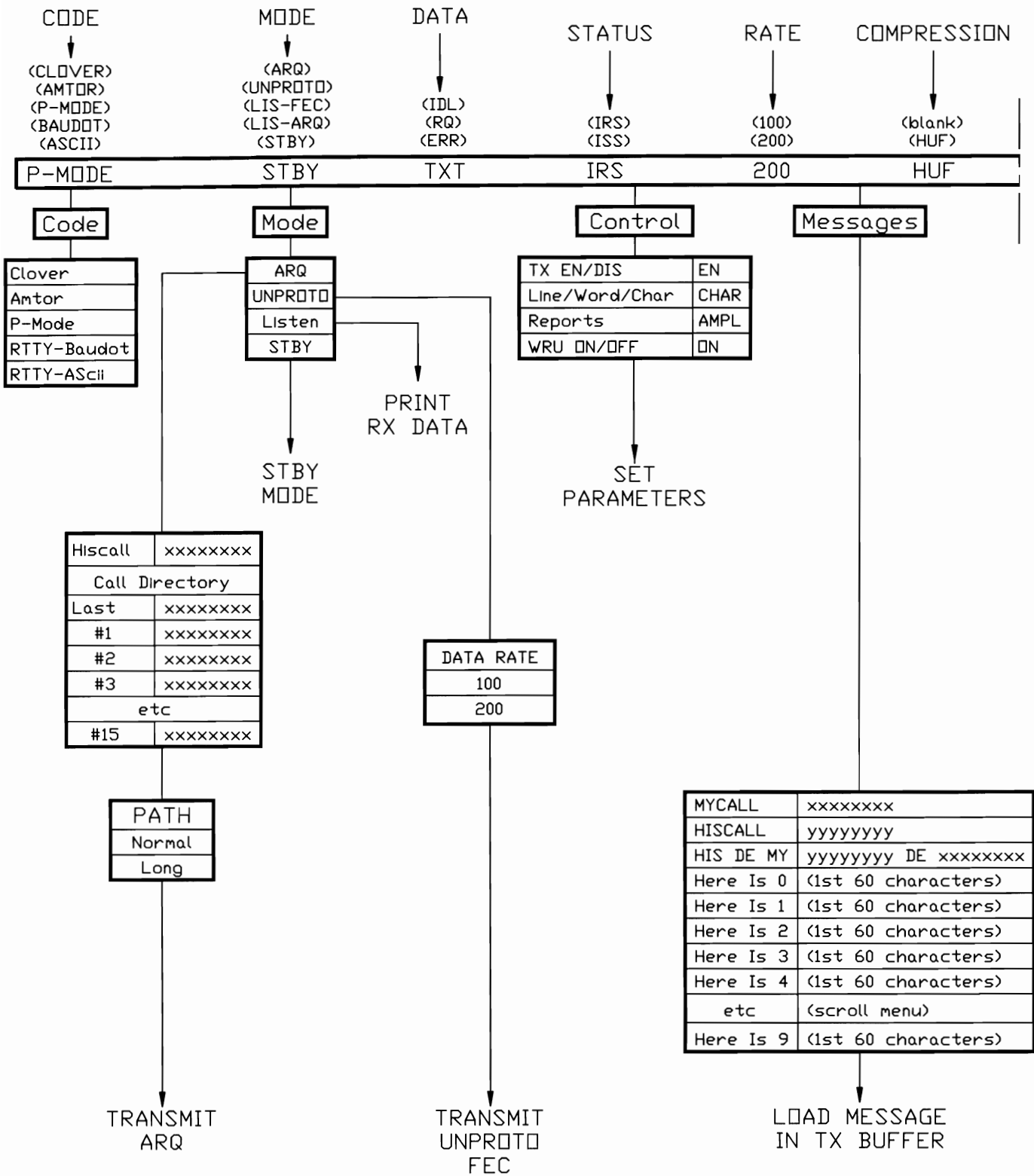

Figure 4.7 Main Menu Tree for P-Mode (left side)

4.5 Configuration Screens

DXP38.EXE includes 3 Configuration Menu pages. Page 1 shows CLOVER-II and general system operating parameters. Page 2 shows all ten HERE IS programmable messages and the Call Sign directory. Page 3 shows FSK-mode parameters (RTTY, AMTOR, & P-Mode).

Software Version Numbers: The "VERSIONS" box in Page 1 of the Configuration menu includes fields to show the version number of all HAL software in use. If you require assistance from the factory, it is very important that you be able to state the software version numbers in use.

Configuration Files: A new Configuration file (DXP38.CFG) may be saved from each of the three Configuration menus and when exiting DXP38.EXE. The exact code, mode, and other parameters as of that time are saved in the *.CFG file. You may also set up multiple configuration files for different operations if you wish. All configuration files must use the ".CFG" extension and have a legal DOS file name (8 characters maximum). You may select or save custom configuration files via any configuration menu. You may also start DXP38.EXE using a custom configuration file in the following manner:

```
C:\DXP38>DXP38 MYCONFIG.CFG [Enter]
```

where "MYCONFIG" is the name of a custom configuration file.

CAUTION: The internal format of .CFG files changes with each revision of DXP38.EXE. *Do not attempt to use old .CFG files after loading a new version of DXP38.EXE.*

Figure 4.8 shows Page 1 of the Configuration Menu. Use this menu to set CLOVER operating parameters, common System parameters, screen colors and to view the software versions in use.

Figure 4.9 shows Page 2 of the Configuration Menu. Use this menu to view and/or change the contents of the HERE IS messages, MYCALL, HISCALL, and the HISCALL Directory.

Figure 4.10 shows Page 3 of the Configuration Menu. Use this menu to view or change the parameters for the FSK modes - RTTY, AMTOR, or P-Mode.

Configuration — DXP38.CFG

<table border="1" style="width: 100%; border-collapse: collapse;"> <tr><th colspan="2" style="text-align: center;">FEC</th></tr> <tr><td>Modulation</td><td>QPSM</td></tr> <tr><td>Code Effic</td><td>60%</td></tr> <tr><td>Block Size</td><td>85</td></tr> </table>	FEC		Modulation	QPSM	Code Effic	60%	Block Size	85	<table border="1" style="width: 100%; border-collapse: collapse;"> <tr><th colspan="2" style="text-align: center;">ADAPTIVE ARQ</th></tr> <tr><td>Auto Bias</td><td>NORMAL</td></tr> <tr><td>Connect Retry</td><td>10</td></tr> <tr><td>Fail Retry</td><td>20</td></tr> <tr><td>Chat Count</td><td>1</td></tr> </table>	ADAPTIVE ARQ		Auto Bias	NORMAL	Connect Retry	10	Fail Retry	20	Chat Count	1	<table border="1" style="width: 100%; border-collapse: collapse;"> <tr><th colspan="2" style="text-align: center;">LISTEN</th></tr> <tr><td>Listen Mode</td><td>DN</td></tr> </table>	LISTEN		Listen Mode	DN																								
FEC																																																
Modulation	QPSM																																															
Code Effic	60%																																															
Block Size	85																																															
ADAPTIVE ARQ																																																
Auto Bias	NORMAL																																															
Connect Retry	10																																															
Fail Retry	20																																															
Chat Count	1																																															
LISTEN																																																
Listen Mode	DN																																															
<table border="1" style="width: 100%; border-collapse: collapse;"> <tr><th colspan="2" style="text-align: center;">SYSTEM</th></tr> <tr><td>UTC Offset</td><td>0</td></tr> <tr><td>Time Zone</td><td>UTC</td></tr> <tr><td>Text Entry</td><td>WORD</td></tr> <tr><td>End Of Line</td><td>CR LF</td></tr> <tr><td>TX Buffer</td><td>ENABLE</td></tr> <tr><td>Scan Control</td><td>CONT</td></tr> <tr><td>CW ID</td><td>OFF</td></tr> <tr><td>AF Channel</td><td>4</td></tr> <tr><td>Reports</td><td>AMPL</td></tr> <tr><td>Echo Enable</td><td>DN</td></tr> <tr><td>Printer</td><td>OFF</td></tr> <tr><td>Print Squelch</td><td>DN</td></tr> <tr><td>Print Squelch</td><td>68</td></tr> <tr><td>COM Port</td><td>COM1</td></tr> </table>	SYSTEM		UTC Offset	0	Time Zone	UTC	Text Entry	WORD	End Of Line	CR LF	TX Buffer	ENABLE	Scan Control	CONT	CW ID	OFF	AF Channel	4	Reports	AMPL	Echo Enable	DN	Printer	OFF	Print Squelch	DN	Print Squelch	68	COM Port	COM1	<table border="1" style="width: 100%; border-collapse: collapse;"> <tr><th colspan="2" style="text-align: center;">SPLIT SCREEN</th></tr> <tr><td>Option</td><td>2 TX LINES</td></tr> </table>	SPLIT SCREEN		Option	2 TX LINES	<table border="1" style="width: 100%; border-collapse: collapse;"> <tr><th colspan="2" style="text-align: center;">VERSIONS</th></tr> <tr><td>DXP38.EXE</td><td>V4.1</td></tr> <tr><td>DXP38.S28</td><td>V1.0</td></tr> <tr><td>DXP38.LDD</td><td>V1.0</td></tr> <tr><td>Boot ROM</td><td>V1.0</td></tr> <tr><td>Product ID</td><td>3800</td></tr> </table>	VERSIONS		DXP38.EXE	V4.1	DXP38.S28	V1.0	DXP38.LDD	V1.0	Boot ROM	V1.0	Product ID	3800
SYSTEM																																																
UTC Offset	0																																															
Time Zone	UTC																																															
Text Entry	WORD																																															
End Of Line	CR LF																																															
TX Buffer	ENABLE																																															
Scan Control	CONT																																															
CW ID	OFF																																															
AF Channel	4																																															
Reports	AMPL																																															
Echo Enable	DN																																															
Printer	OFF																																															
Print Squelch	DN																																															
Print Squelch	68																																															
COM Port	COM1																																															
SPLIT SCREEN																																																
Option	2 TX LINES																																															
VERSIONS																																																
DXP38.EXE	V4.1																																															
DXP38.S28	V1.0																																															
DXP38.LDD	V1.0																																															
Boot ROM	V1.0																																															
Product ID	3800																																															
<table border="1" style="width: 100%; border-collapse: collapse;"> <tr><th colspan="2" style="text-align: center;">DISPLAY COLORS</th></tr> <tr><td>RX Text</td><td>RX</td></tr> <tr><td>TX Text</td><td>TX</td></tr> <tr><td>Status Text</td><td>STAT</td></tr> <tr><td>Help Text</td><td>HELP</td></tr> <tr><td>CMD Text</td><td>CMD</td></tr> </table>	DISPLAY COLORS		RX Text	RX	TX Text	TX	Status Text	STAT	Help Text	HELP	CMD Text	CMD	<table border="1" style="width: 100%; border-collapse: collapse;"> <tr><th colspan="2" style="text-align: center;">OPTIONS</th></tr> <tr><td>Edit Config</td><td>Page 1</td></tr> <tr><td>Go To</td><td>Page 2</td></tr> <tr><td>Go To</td><td>Page 3</td></tr> <tr><td>Go To</td><td>Main</td></tr> <tr><td>Save Config</td><td></td></tr> <tr><td>Load Config</td><td></td></tr> </table>	OPTIONS		Edit Config	Page 1	Go To	Page 2	Go To	Page 3	Go To	Main	Save Config		Load Config																						
DISPLAY COLORS																																																
RX Text	RX																																															
TX Text	TX																																															
Status Text	STAT																																															
Help Text	HELP																																															
CMD Text	CMD																																															
OPTIONS																																																
Edit Config	Page 1																																															
Go To	Page 2																																															
Go To	Page 3																																															
Go To	Main																																															
Save Config																																																
Load Config																																																

ENTER To Select Option ↑↓ To Move ESC To Exit Configuration

Figure 4.8 Configuration Menu Page 1 (CLOVER & System)

Configuration — DXP38.CFG

MESSAGES		
0 (here is 0)		<
1 (here is 1)		<
2 (here is 2)		<
3 (here is 3)		<
4 (here is 4)		<
5 (here is 5)		<
6 (here is 6)		<
7 (here is 7)		<
8 (here is 8)		<
9 (here is 9)		<

MYCALL	CALL SIGN	SEL-CAL
(mycall)	(call7)	(scal7)
HISCALL Directory		
Last	(last hiscall)	last scal
#1	(call1)	(scal1)
#2	(call2)	(scal2)
#3	(call3)	(scal3)
#4	(call4)	(scal4)
#5	(call5)	(scal5)
#6	(call6)	(scal6)

CALL SIGN	SEL-CAL
#7	(scal7)
#8	(scal8)
#9	(scal9)
#10	(scal10)
#11	(scal11)
#12	(scal12)
#13	(scal13)
#14	(scal14)
#15	(scal15)

OPTIONS	
Edit Config	Page 2
Go To	Page 3
Go To	Page 1
Go To	Main
Save Config	
Load Config	

Enter To Select Option ↑↓ To Move ESC To Exit Configuration

Figure 4.9 Configuration Menu - Page 2 (HERE IS & HISCALL)

FSK MODES — Configuration — DXP38.CFG

AMTOR		P-MODE		BAUDOT		ASCII	
TXEN On/Off	ON	TXEN On/Off	ON	TXEN On/Off	ON	TXEN On/Off	ON
WORD/CHAR	WORD	WORD/CHAR	WORD	WORD/CHAR	WORD	WORD/CHAR	WORD
NORM/REV	NORM	EOL	CR LF	NORM/REV	NORM	NORM/REV	NORM
EOL	CR LF LTRS	CS DELAY	30	EOL	CR LF LTRS	EOL	CR LF
WRU On/Off	OFF	MAX DOWN	6	SYNC On/Off	ON	SYNC On/Off	OFF
Time Out	32	MAX UP	3	USDS On/Off	ON	RATE	110
TD	10	MAX TRY	2	RATE	45	PTT ON	20
CD	50	MAX ERROR	80	CODE No2/US	US	PTT OFF	20
LETTER CASE	U	MAX ARQ SUM	30	PTT ON	20		
MY 476 SCAL	SCAL	FEC Repeats	2	PTT OFF	20		
MY 625 SCAL	SELCALL	HUFFMAN	ON				
Group Call	CQCQ						

FSK TONES			
AMTOR/BAUDOT/ASCII			
MARK	2125	Center	2210
SPACE	2295	Shift	170
P-MODE			
FREQ 1	2100	Center	2200
FREQ 2	2300	Shift	200

OPTIONS	
Edit Config	Page 3
Go To	Page 1
Go To	Page 2
Go To	Main
Save Config	
Load Config	

FSK POLARITY	NORM
--------------	------

ENTER To Select Option ↑↑ To Move ESC To Exit Configuration

Figure 4.10 Configuration Menu - Page 3 (FSK Modes)

4.6 Hot-Keys

DXP38.EXE uses the function keys (F1 through F11) and Alt-letter keys (Alt-A through Alt-Z) for rapid control of important operating parameters. Due to the finite limit on the number of "hot-key" combinations available, some keys have different functions as the code is changed.

4.6.1 Function Hot-Keys:

Table 4.1 shows the operation of each function key for each code. Three possible levels are possible for each function key: the "F#" itself, Alt-F#, and Ctrl-F#. Not all possible combinations are used for each code and whenever possible similar operations carry-over between codes.

4.6.2 Alt-letter Hot-Keys:

Table 4.2 shows the operation of each Alt-letter key for each code.

FN Key	BAUDOT	ASCII	CLOVER	AMTOR	P-MODE
F1	Enter CMD Mode	Enter CMD Mode	Enter CMD Mode	Enter CMD Mode	Enter CMD Mode
Alt-F1	Enter CMD Mode	Enter CMD Mode	Enter CMD Mode	Enter CMD Mode	Enter CMD Mode
Ctrl-F1	Enter CMD Mode	Enter CMD Mode	Enter CMD Mode	Enter CMD Mode	Enter CMD Mode
F2	Load HIS DE MY	Load HIS DE MY	Load HIS DE MY	Load HIS DE MY	Load HIS DE MY
Alt-F2					
Ctrl-F2	Toggle Split Screen	Toggle Split Screen	Toggle Split Screen	Toggle Split Screen	Toggle Split Screen
F3	Load HISCALL	Load HIS callsign	Load HIS callsign	Load HIS callsign	Load HIS callsign
Alt-F3				Change HIS SELCAL	
Ctrl-F3	Change HIS callsign	Change HIS callsign	Change HIS callsign	Change HIS callsign	Change HIS callsign
F4	Load MYCALL to TX	Load MYCALL to TX	Load MYCALL to TX	Load MYCALL to TX	Load MYCALL to TX
Alt-F4	Load CWID to TX	Load CWID to TX	Load CWID to TX	Load CWID to TX	Load CWID to TX
Ctrl-F4	Force CWID	Force CWID	Force CWID	Force CWID	Force CWID
F5 #	Load HERE IS #	Load HERE IS #	Load HERE IS #	Load HERE IS #	Load HERE IS #
Alt-F5	Toggle LSB/USB	Toggle LSB/USB		Toggle LSB/USB	Toggle LSB/USB
Ctrl-F5	Program HERE IS#	Program HERE IS#	Program HERE IS#	Program HERE IS#	Program HERE IS#
F6				Load Over	Load Over
Alt-F6					
Ctrl-F6				Force Over (IRS)	Force Over (IRS)
F7	Insert END (ZZZZ)	Insert END (ZZZZ)	Insert END (ZZZZ)	Insert END (ZZZZ)	Insert END (ZZZZ)
Alt-F7			Panic Kill		
Ctrl-F7			Panic Kill	Panic Kill	Panic Kill
F8			Listen On/Off	Listen On/Off	Listen On/Off
Alt-F8	Tone Test	Tone Test		Tone Test	Tone Test
Ctrl-F8					
F9			Initiate ARQ Link	Initiate ARQ Link	Initiate ARQ Link
Alt-F9			Initiate ARQ CQ Call		
Ctrl-F9			Answer ARQ CQ Call		
F10	TX Buffer EN/DIS	TX Buffer EN/DIS	TX Buffer EN/DIS	TX Buffer EN/DIS	TX Buffer EN/DIS
Alt-F10	TX Buffer EN/DIS	TX Buffer EN/DIS	TX Buffer EN/DIS	TX Buffer EN/DIS	TX Buffer EN/DIS
Ctrl-F10	TX Buffer EN/DIS	TX Buffer EN/DIS	TX Buffer EN/DIS	TX Buffer EN/DIS	TX Buffer EN/DIS
F11					
Alt-F11					
Ctrl-F11	Set Tone Freq	Set Tone Freq	Set Tone Freq	Set Tone Freq	Set Tone Freq

Table 4.1 - Function HOT-KEY Assignments

Alt Key	BAUDOT	ASCII	CLOVER	AMTOR	P-MODE
Alt-A	Tune/Status Indic	Tune/Status Indic	Tune/Status Indic	Tune/Status Indic	Tune/Status Indic
Alt-B	Load Time & Date	Load Time & Date	Load Time & Date	Load Time & Date	Load Time & Date
Alt-C	End HERE IS Prog	End HERE IS Prog	End HERE IS Prog	End HERE IS Prog	End HERE IS Prog
Alt-D	Load Date	Load Date	Load Date	Load Date	Load Date
Alt-E	Save Files to Disk	Save Files to Disk	Save Files to Disk	Save Files to Disk	Save Files to Disk
Alt-F	Reformat TX buffer	Reformat TX buffer	Reformat TX buffer	Reformat TX buffer	Reformat TX buffer
Alt-G	Force LTRS			Force LTRS	
Alt-H	Access HELP	Access HELP	Access HELP	Access HELP	Access HELP
Alt-I	CW ID ON/OFF	CW ID ON/OFF	CW ID ON/OFF	CW ID ON/OFF	CW ID ON/OFF
Alt-J	Stop Disk Operation	Stop Disk Operation	Stop Disk Operation	Stop Disk Operation	Stop Disk Operation
Alt-K	Delete Line	Delete Line	Delete Line	Delete Line	Delete Line
Alt-L	Load File in TX Buf	Load file in TX Buf	Load file in TX Buf	Load file in TX Buf	Load file in TX Buf
Alt-M	Change MYCALL	Change MYCALL	Change MYCALL	Change MYCALL	Change MYCALL
Alt-N	NORM/REV	NORM/REV		NORM/REV	
Alt-O	Print Squelch	Print Squelch	TX Test Mode On/Off		
Alt-P	Printer On/Off	Printer On/Off	Printer On/Off	Printer On/Off	Printer On/Off
Alt-Q	Load QBF Message	Load QBF Message	Load QBF Message	Load QBF Message	Load QBF Message
Alt-R	Select RX Buffer	Select RX Buffer	Select RX Buffer	Select RX Buffer	Select RX Buffer
Alt-S	RTTY Data Rate	RTTY Data Rate	Increment ARQ Bias		Change ARQ Baud
Alt-T	Load Time	Load Time	Load Time	Load Time	Load Time
Alt-U	Clear RX Buffer	Clear RX Buffer	Clear RX Buffer	Clear RX Buffer	Clear RX Buffer
Alt-V	Clear TX Buffer	Clear TX Buffer	Clear TX Buffer	Clear TX Buffer	Clear TX Buffer
Alt-W	Delete Word	Delete Word	Delete Word	Delete Word	Delete Word
Alt-X	Select TX Buffer	Select TX Buffer	Select TX Buffer	Select TX Buffer	Select TX Buffer
Alt-Y	Autopower On/Off	Autopower On/Off	Autopower On/Off	Autopower On/Off	Autopower On/Off
Alt-Z	Load MARS Time Group	Load MARS Time Group	Load MARS Time Group	Load MARS Time Group	Load MARS Time Group

Table 4.2 - Alt-letter HOT-KEY Assignments

4.7 File Operations

DXP38.EXE software provides full computer file access. Receive data or text may be saved in a computer file, computer files may be transmitted. Text files may also be loaded into the transmit buffer and viewed, transmitted, and/or edited. The hard disk directory can be viewed, directory changed, files deleted, names changed, or copied. Please refer to the Files Menu shown in Figure 4.3. Use of the CONFIGURATION option has already been discussed in section 4.5.

4.7.1 Load TX Buffer

This option is useful for viewing and possibly editing text files before they are sent. The character set is limited to the "viewable" ASCII characters permitted by your computer video system. This mode is ideal for most text communications and works equally well in all data modes. However, note that the transmit buffer is limited in size to 250 lines. Larger text files will be truncated and only first 250 lines will be loaded and/or sent (use Send From Disk for larger files – see section 4.7.4). Text files loaded into the transmit buffer and then sent will also have the End-Of-Line (EOL) sequence modified to the sequence you have chosen for each data mode. For example, computer-created *.TXT files generally use only a CR (Carriage Return) to end a line and start a new line. When you load a file into the transmit buffer, the file EOL is executed and each screen line appears correctly. If this message is now sent via Baudot code, for example, the Baudot EOL (section 4.7.4) from page 3 of the Configuration Menu will be added to the end of each line. If sent in AMTOR, the EOL sequence for AMTOR will be used instead and so on. This procedure assures that messages have the correct EOL sequence for the code you have chosen. However, if you do not wish for the EOL sequence to be changed at all from that used in the original computer file, use the Send From Disk option (4.7.4).

4.7.2 Save To Disk

All received data may be saved to disk as a computer file. Data bytes or characters are saved exactly as received in the disk file, including End Of Line (EOL) sequence and errors that may have been caused by noise, poor typing, etc. The receive file may be either "continuous" or "sequential". In addition, a portion or all of the RX or TX screen buffers may be saved as a disk file. Finally, the on-screen CLOVER-II channel statistics (SNR, FRQ, PHS, ERR, etc) may be saved to disk for later study.

Save To Disk – Continuous: The continuous save option stores all received data in one long file and will continue until you enter the Stop Send/Save command or a maximum of 20,000 characters have been stored. When file save is active, the file name is shown on the right end of the top line of the screen. The file name may include drive, path, and extension.

Save To Disk – Sequential: The sequential save option may be used to create separate receive files for each message. The file storage assumes that the standard "NNNN" sequence is sent at the end of each message. In sequential mode, when "NNNN" is received, the current receive data file is closed and a new file is opened. In this case, you may specify the drive, path, and file name, but the file extension will be a 3 digit number starting at *.001, incremented upon each reception of "NNNN".

Receive Buffer Block Save: This option allows you to "look-back" into text you have previously received and save all or a portion of what you see in the receive buffer. The menu commands prompt setting the start save and stop save points in the receive block. You may specify drive, path, file name, and extension.

Transmit Buffer Block Save: This option allows you to set start and stop save points and then store the selected TX buffer text as a disk file. This feature allows you to create new file messages in the transmit buffer using the DXP38 editor. You may specify drive, path, file name, and extension.

Record Channel Statistics: This feature is usable only when using the CLOVER-II data mode. All channel statistics of a CLOVER link are stored in an ASCII data file that is compatible with most spread sheet programs. The file name is created automatically in the following format:

File Name = MMDDHHmm.TST

where, MM = month, DD = days, HH = hour, and mm = start minute. The "TST" extension is used for all statistics files. There are three user entry fields at the beginning of each statistics file:

FREQ [] (6 characters maximum)
 NAME [] (16 characters maximum)
 OTHER[] (16 characters maximum)

Data recording starts after the last entry field has been completed. The data format is:

[FREQ],[NAME],[OTHER][cr][lf]
 [time],[my/his],[mod],[bias],[rate],[snr],[frq],[phs],[ecc],[tpr],[cr][lf]
 [time],[my/his],[mod],[bias],[rate],[snr],[frq],[phs],[ecc],[tpr],[cr][lf]
 [time],[my/his],[mod],[bias],[rate],[snr],[frq],[phs],[ecc],[tpr],[cr][lf]
 etc.

The data fields are:

time = HHmmss (hours/minutes/seconds)
 my = MYCALL (8 characters maximum)
 his = HISCALL (8 characters maximum)
 mod = Modulation (BPSM, QPSM, 8PSM, 8P2A, 16P4A)
 bias = 1 (Robust), 2 (Normal), 3 (Fast)
 rate = Throughput in bytes-per-second (00-99)
 snr = Signal-To-Noise Ratio (00-99 dB)
 frq = Frequency Offset (0 - \pm 30 Hz)
 phs = Phase Dispersion (000-256)
 ecc = Error Corrector Loading (00-100; XX for EC exceeded)
 tpr = Not used

The statistics data file may be directly imported into a spread sheet as an ASCII file with comma delimiters (the comma creates a new column in the spread sheet). The results may then be plotted or otherwise studied. If you desire further information on this topic, you may wish to obtain copies of HAL documents on CLOVER-II (E2006) and CLOVER Data Link Statistics.

4.7.3 Stop Send / Save

Use this menu command to stop file send or save activities. When storing received data to disk, the Stop Save command closes the file immediately and no further information will be saved. When sending a file from disk, the Stop command immediately ceases any further transfer of file data to the DXP-38 modem, but data that is contained in the DXP-38 TX data buffer will continue to be sent until the buffer is empty. This may be a substantial amount of data when CLOVER-II is used. If an immediate stop send and stop transmit action is needed, use the "panic kill", **[Alt][F7]** or **[Ctrl][F7]**.

4.7.4 Send From Disk

The Send From Disk feature may be used to send any computer file. Two options are provided – Send Text File and Send Binary File.

Send From Disk – Text: Use the “Text” option to send text files in any mode. The data is sent exactly as stored in the disk file, without any modification to the End Of Line sequence (EOL). Compression is not used in this mode.

Send From Disk – Binary: Use the “Binary” option to send all data files when using CLOVER-II. All 8 bits of each data byte are sent in “binary mode” and all data is sent using PK-Ware compression. This mode may be used to send ANY file stored in your computer, including data, image, executable, and text file. This is actually a file-transfer mode and results in creation of this file at the other station. If a file of this name already exists at the other station, a duplicate file message is shown on the screen and the file transfer is cancelled. If you still wish to transfer this file, either rename it at the sending end or delete or rename the file at the receiving end. File transfer information is displayed in the lower section of the screen while the file transfer is in progress. Binary file transfer is automatic and even if the link fails, the stopping point is preserved and transfer will resume at that point when a successful link is again made.

4.7.5 Directory

The Directory file option provides access to computer file in DOS. A short-form directory listing is displayed to conserve screen space. The “Next Page” option allows viewing all files in a large directory. The menu options let you change directories, and delete, rename, or copy a file.

4.7.6 Load DXP38

The Load DXP38 file option allows the user to upload current versions of `_S28` and `_LOD` into the DXP38 flash memory. Users upgrading to current versions of DXP38.EXE should also upgrade the DXP38 firmware by uploading these files into the DXP38. The steps are:

STEP	ACTION
1	Press [F1] . The command line appears.
4	Press F for FILE MENU (or highlight using arrow keys). Press [ENTER] .
5	Highlight Load DXP38 using arrow keys. Press [ENTER] .
4	Load menu screen appears. Type DXP38.S28 [ENTER] .
5	The DXP38 systematically lights the cross tuning display while DXP38.EXE program displays a file transfer meter. When file transfer is completed, DXP38.EXE displays DONE.
6	To Load the <code>_LOD</code> file type DXP38.LOD [ENTER] . Step 5 repeats.

4.8 TX Buffer Editor

DXP38.EXE includes a *simple* text editor that may be used to correct typing errors and do limited formatting of text before transmissions. The editor may also be used to correct errors caused by noise or interference before re-transmitting recorded text. Table 4.3 shows TX Buffer edit keys:

Table 4.3
Transmit Buffer Edit Keys

Key	Operation
[ALT]-X	Set scroll operation to the transmit buffer
[left arrow]	Move cursor left one character
[Ctrl]-[left]	Move cursor left one word
[right arrow]	Move cursor right one character
[Ctrl]-[right]	Move cursor right one word
[up arrow]	Move cursor up one line
[down arrow]	Move cursor down one line
[PgUp]	Move cursor up ten lines (or up to first line)
[PgDn]	Move cursor down ten lines (or to last line)
[Home]	Move cursor to beginning of current line
[Ctrl]-[Home]	Move cursor to line 1, character 1
[End]	Move cursor to end of current line
[Ctrl]-[End]	Move cursor to last text line in TX buffer
BS ([Ctrl]-H)	Delete one character to left of cursor
[Back arrow]	Delete one character to left of cursor
[Del]	Delete character at cursor
[Ins]	Toggle between Insert and Overtyping modes
[Alt]-F	Reformat current paragraph
[Alt]-K	Delete current line
[Alt]-W	Delete word at cursor
[Alt]-V	Clear entire transmit buffer

4.9 OPERATING RTTY

4.9.1 RTTY Codes

DXP38.EXE includes two RTTY modes - 5-bit Baudot at data rates of 45, 50, 57, or 75 baud and 8-bit ASCII at 75 or 110 baud. Either "U.S. Military Baudot" or "CCITT No. 2" Baudot character set may be selected via Page 3 of the CONFIGURATION menu.

4.9.2 Starting RTTY

Use the following steps to start RTTY modes:

STEP	ACTION
1	Press [F1] . The COMMAND menu will appear with CODE highlighted.
2	Press [ENTER] . The CODE menu will be shown.
3	Use the [up-arrow] or [down-arrow] keys to highlight RTTY-BAUDOT or RTTY-ASCII.
4	Press [ENTER] .

4.9.3 RTTY Data Rates

The baud and WPM equivalents for each code and speed are shown in Table 4.4

Table 4.4
RTTY Data Rates and Speeds

CODE	BAUD	WPM	COMMENTS
BAUDOT	45	60	"Standard" Baudot Speed
BAUDOT	50	66	"European" Baudot Speed
BAUDOT	57	75	"Weather" Baudot Speed
BAUDOT	75	100	Most Baudot "Mailboxes"
ASCII	75	67	Non-standard Speed
ASCII	110	100	"Standard" ASCII Speed

A special "Hot Key" is included for rapid RTTY data rate changes. Type **[Alt]-S** to increment through the available RTTY data rates. Each press of **[Alt]-S** increases the rate one "notch".

4.9.4 Control Menu Options

The available CONTROL menu options are shown in Table 4.5

Table 4.5
RTTY Control Options

TX EN/DIS	EN
Line/Word/Char	WORD
Reports	AMPL
Norm/Rev	NORM
SYNC ON/OFF	ON
USOS ON/OFF	ON

Note: "USOS" (UnShift On Space) is available only for Baudot code.

TX EN/DIS: This option controls the state of the transmit buffer and the PTT transmit/receive control signal. In "DIS" (DISabled) state, the transmitter will not be turned ON and text typed into the transmit buffer will be held until this control is set to "EN" (ENabled). "DIS" is the normal receive state. This control changes from "DIS" to "EN" each time this option is selected and **[Space Bar]** is typed. "Hot-key" **[F10]** also toggles the state of this control. Key **[F10]** is normally used in this manner to control the transmit/receive state of your RTTY station.

The "EN" (ENabled) condition actually has two states:

1. If you have pre-typed text into the transmit buffer and the state is changed from "DIS" to "ACT", the transmitter is turned ON (PTT line to TX condition) and text is sent at the chosen code and data rate. There is a short delay of Mark- only condition at the start to assure that your transmit relays are actually in transmit state before data is sent.

The transmitter will remain "on-the-air" and text will be sent for as long as text remains to be sent. After the last text character has been sent, the PTT line reverts to receive and you will again be able to receive RTTY. In this case, the state reverts to "EN" and "RX" since there is

no text to be sent. The send-to-receive transition is also affected by WORD mode and SYNChronous idle as will be explained shortly.

An immediate return to receive may be made at any time by typing **[F10]** again or by accessing the COMMAND and CONTROL menus and selecting the "TX EN/DIS" option.

2. If there is no pre-typed text in the transmit buffer and the state is changed from "DIS" to "EN", DXP38.EXE and your radio will remain in receive condition. However, the state will immediately change to transmit (ACT) as soon as you type the first character into the transmit buffer. This mode is analogous to "full break-in". In actual use, most operators prefer to always set this option to "DIS" except when it is their turn to transmit. This allows pre-typing your response while receiving the other station ("ASR" mode).

IT IS SIMPLEST TO USE [F10] TO TOGGLE BETWEEN TX AND RX IN RTTY.

SYNC: The SYNC option is often called "SYNC-IDLE" (or "diddle"). When ON, non-printing characters will be inserted into the transmit data stream if your typing has not produced a word or character to be transmitted.

In Baudot RTTY, the "LTRS" (Letters) character is sent; in ASCII, the "NULL" character is used. Both are "non-printing" characters and may help maintain receive synchronization of your RTTY signal at the other station.

NORM/REV: This option controls the polarity of your RTTY signal. It sets the polarity of both the receive and transmit data sections of the DXP38. The default settings for RTTY and AMTOR are:

Polarity:	NORM (Mark = lower frequency tone)
TONES:	Mark = 2125 Hz; Space = 2295 Hz Shift = 170 Hz; Center = 2210 Hz
RADIO:	LSB mode

Baudot-RTTY, ASCII-RTTY, and AMTOR all follow these standards.

NOTES: "Hot-Key" **[Alt]-N** also changes **NORM/REV**.
"Hot-Key" **[F6]** toggles **ONLY** the receive polarity.

Baudot UnShift On Space (USOS): This is a special option only for Baudot RTTY. Baudot code uses its 5-bit code combinations twice - once for letters and again for numbers and symbols. A special pair of Baudot characters set the receiving terminal to the correct "case" - Letters (LTRS) or Figures (FIGS). Noise can be interpreted as a FIGS Baudot character, setting the receiver printer or display to FIGS case by accident and garbling the data received after that point. If enable, USOS will return the receive display or printer to LTRS case after the reception of a space character. While this is a very useful feature when receiving text, you may wish to turn USOS OFF when receiving strings of numbers, particularly if the sending station does not send new FIGS characters frequently (a frequent problem in military systems and when receiving weather sequence reports).

Baudot FORCE LTRS Key: In addition to the USOS option, the **[Alt]-G** key combination may be used to force your Baudot receive terminal to LTRS case at any time. If you actively watch the print as received, you may prefer to use **[Alt]-G** rather than USOS.

4.9.5 Configuration Menu Options

Page 3 of the configuration menu provides display and access to a variety of RTTY options. Separate parameters are provided for Baudot RTTY and ASCII RTTY. These menus are a second way to view and set TXEN, Line/Word/Char mode, NORM/REV polarity, SYNC IDLE, and USOS features (Baudot only). The data rate may also be set via the page 3 configuration menus.

To access and change an item on the Configuration menu, use the right-arrow key to select the desired menu, the down arrow to select the item in that menu, and then use the space bar to cycle through the available options or enter a number as indicated. Other RTTY parameters that may be set include:

EOL: The End Of Line (EOL) characters may be set for both Baudot and ASCII modes. The selected EOL sequence can include CR (Carriage Return), LF (Line Feed), and LTRS (Letters – Baudot only). The recommend standard EOL sequences are CR LF LTRS in Baudot and CR LF in ASCII. However, some Baudot operators prefer CR CR LF LTRS. Some computer programs prefer CR only as the ASCII EOL.

CODE No2/US: The DXP38 Baudot code may be set to use either the CCITT No. 2 5-unit code or the US Military Interoperation Baudot Code. All letters and numbers are the same in both versions of the code. The differences are:

Table 4.6
Baudot Code Differences

CODE	US Baudot	CCITT No.2
FIGS-D	\$ (dollar sign)	\$ (dollar sign, not designated by CCITT)
FIGS-H	# (number sign)	# (number sign, not designated by CCITT)
FIGS-J	' (apostrophe)	BELL
FIGS-S	BELL	' (apostrophe)
FIGS-V	; (semi-colon)	= (equal sign)
FIGS-Z	" (quotation)	+ (plus sign)

PTT ON: PTT ON is a programmable time delay that is used to compensate for the turn-on time of the transmitter. The number programmed is the delay in milliseconds (ms) between setting the PTT line to ground (transmit state) and the release of data to be transmitted. Use this delay to prevent garbling of characters during the time that the transmitter relays are switching. The factory default value is 20 ms; PTT ON may be set to a number between 01 and 99 ms.

PTT OFF: PTT OFF is a programmable time delay that is used to compensate for the turn-off time of the transmitter. The number programmed is the delay in milliseconds (ms) between sending the last transmit data byte and releasing the PTT line to open (receive state). This delay is often used to prevent TX/RX switching during short pauses when typing text. The factory default value is 20 ms; PTT OFF may be set to a number between 01 and 99 ms.

FSK ATC: RTTY includes an Automatic Threshold Control (ATC) feature which will automatically compensate for differential Mark/Space fading caused by ionospheric multi-path distortion. ATC works best when the data is sent at a constant rate, a continuous stream of data or text. ATC may cause errors when receiving very irregular hand-typed text. The factory setting of ATC ON is recommended except when receiving hand-typed data.

FSK POLARITY: This menu option controls the FSK Transmit Output signal as discussed in section 2.2.4 of this manual. Please refer to Table 2.3 on Page 2-5 for a full explanation of how to use this option.

FSK TONES: The FSK transmit and receive tone frequencies can be set to any frequency between 500 Hz and 3000 Hz in 1.0 Hz increments. The frequencies can be specified as either Mark and Space tone frequencies, or the center frequency and shift frequency. Separate sets of Mark/Space frequencies are provided for RTTY / AMTOR and P-Mode.

4.9.6 Print Squelch

RTTY includes a "print squelch" control that can be used to suppress receive screen display of "garbage characters" that may result from reception of noise when a valid RTTY signal is not being received. The "print squelch" control functions much like the squelch control on a VHF-FM receiver, but it is a digital keyboard control in DXP38.EXE. Special status indicators and key combinations are provided to control print squelch.

To set PRINT SQUELCH, first be sure that you are NOT in COMMAND mode (no COMMAND menus). Then, type **[Alt]-O**. A new menu will appear in the transmit buffer to set "Print Squelch Level" and "Print Squelch ON/OFF". The Print Squelch level is shown on the four-bar amplitude display by small corner symbols on #1 and #4 tuning bars. The center LED of the front panel crossed LED display is turned ON whenever receive data will be displayed – when the received signal exceeds the Print Squelch threshold or when Print Squelch is turned OFF.

4.9.7 Special RTTY Transmit Keys

Special key combinations are provided to send special RTTY characters. These keys are shown in Table 4.7:

Table 4.7
Special RTTY Transmit Keys

KEY	CHARACTER	NOTES
[Ctrl]-G	Signal Bell	"Diamond" symbol on screen
<	LTRS	Only Baudot and TOR
>	FIGS	Only Baudot and TOR
[Alt]-Y	12 LTRS	Sequence of 12 LTRS

4.10 Operating CLOVER-II

This section describes the steps necessary to operate the DXP38 in the CLOVER-II mode. Unless you are already in CLOVER the following steps are necessary. Always remember to answer **Y** to the Save Configuration question upon exiting DXP38.EXE. If you don't, you will lose all of your setup parameters.

STEP	ACTION
1	Press [F1] . The first COMMAND menu will appear with CODE Highlighted.
2	Press ENTER . The CODE menu will be shown.
3	Use the [up-arrow] or [down-arrow] keys to highlight CLOVER .
4	Press ENTER . The MODE menu will now be shown with send ARQ highlighted.

4.10.1 Tuning A CLOVER Signal

There are four different tuning aids available when using DXP38.EXE, two displayed on the computer screen and two shown by the DXP38 front panel LED array.

STEP	ACTION
1	Use [Alt]-A to access the Amplitude Tuning Bars in the top-left corner of the screen. You should see four bars of varying lengths.
2	Tune the transceiver until all four bars are generally equal in magnitude. When the bars "freeze" and the link message or FEC message appears above them, continue to step 3.
3	Press [Alt]-A to access the Frequency Error Tuning Bar.
4	Check the FRQ column on the right of the screen and the Frequency Error Tuning Bar (See below) to check your tuning error. The FRQ number is the error in Hertz.
5	Make VERY small adjustments to the receiver to reduce the frequency error. It will be a moment before the Frequency Tuning Bar (See below) reflects the change you have made. Repeat this step until you are "close" to the frequency of the sending station. STOP TUNING. (Note 1)

The Frequency Tuning Bar is accessed by pressing **[Alt]-A** from the Amplitude Tuning Bars and is located in the same area of the screen.

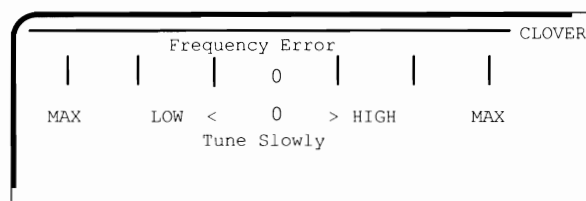

This display is a single scale that indicates the relative frequency difference between you and the station you are listening to and the direction (high or low) of the error. This bar may be used to refine the tuning done using the Amplitude Tuning Bars. The display scale is ± 30 Hz.

DXP-38 Front Panel Tuning Indicator

Crossed X Display: With the display switch in the "M/S" position, the DXP38 front panel "+" display shows the amplitude of each of the four CLOVER tone channels, one channel for each leg of the "+". Typical displays when tuning a CLOVER-II signal are shown in Figure 2.4.

Δf Display: When the display switch is in the " Δf " position, the front panel LEDs operate much like the frequency error screen display except that the vertical axis of the "X" is used to emphasize fine-tuning. Typical displays in Δf mode are shown in Figure 2.5.

Note that CLOVER data can be updated only once per received data block – once every 2.8 seconds in CCB mode and as long as only once every 19.88 seconds in ARQ mode when receiving BPSM modulation. *Tune slowly and carefully!*

4.10.2 RX/TX Status Table

In ARQ mode, CLOVER-II dynamically adjusts its modulation to match the current propagation conditions. The receiving station measures signal parameters, determines the optimum mode, and sends mode change commands to the transmitting station. The measured parameters and transmit waveforms of the two stations are displayed in the numerical table in the upper right section of both tuning screens.

	MOD	SNR	FRQ	PHS	ECC	TPR
MY	16P4A	31	+01	010	00	50
MY	16P4A	32	+03	015	02	50
HIS	8PSM	13	-02	122	10	100
HIS	8PSM	15	-01	110	14	100

Four rows of numbers are displayed, two that show MY station parameters and two rows that show HIS station parameters. In ARQ mode, all four rows are used. The lower MY row of numbers shows data from the last transmission. Similarly, the lower HIS row is the current data; the upper HIS row shows conditions during the previous transmission. The data columns show:

MOD	=	Modulation mode (BPSM through 16P4A)
SNR	=	Detector signal-to-noise ratio (dB)
FRQ	=	Frequency tuning error (\pm 1Hz increments)
PHS	=	Phase dispersion in log units (low numbers are good)
ECC	=	Error correction capacity used (0 to 100%; XX = fail)

This information can be extremely interesting and useful when analyzing propagation conditions. The data may be saved to disk via the Files menu for later analysis (see section 4.7).

NOTES:

1. You may not be able to precisely "zero" the Frequency Tuning Bar on the frequency of the sending station. This is not a problem. Some transceivers tune in 10 Hertz steps.
2. If you are the sending station you should avoid tuning at all after a link is made. The receiving station should use this procedure to refine the link frequency.
3. In CLOVER-II, the CW ID is sent using tone "T2".

4.10.3 Adaptive ARQ Mode

The CLOVER-II Adaptive ARQ mode is a two station point-to-point communications mode using fully adaptive waveform control. The following steps show you how to initiate an ARQ LINK:

STEP	ACTION
1	Press [F9] to begin an ARQ LINK.
2	Type the call sign of the <i>other station</i> in the HISCALL position and press [Enter] or use the [down-arrow] key to select the call of your choice. Press [Enter] to select the call that is highlighted.
3	An ARQ LINK attempt will begin..

Note: Use **[F10]** to toggle the TX EN/DIS to EN to enable the transmit buffer.

ARQ LINK: During an ARQ LINK, data is transmitted in two ways. When both stations are "chatting" and the transmitted data from both sides is relatively short, the data is sent as part of each (CCB CLOVER Control Block). When the TX buffer of either station reaches a certain level of fill, Clover begins sending the information in a series of data blocks, followed by a CCB. Once the data in the TX buffer is sent, CLOVER returns to the CCB "chat" mode.

Data can be pre-programmed in the ten programmable messages, or as text files on a disk. You can use Load TX Buffer on the Files menu or press **[Alt]-L** to load a file from disk that does not exceed the 250 line capacity of the buffer. For files larger than the TX buffer, use the Send From Disk option of the Files menu. Files sent that way are transmitted directly, rather than through the TX buffer.

ARQ END Commands: There are two methods of ending a CLOVER-II ARQ Link

- Pressing **[F7]** (END) breaks the link in the normal manner after all pending text has been sent. The link does not drop until the other station has confirmed receipt of the disconnect request. You will see "ZZZZ" appear when **[F7]** is typed while text remains in the TX buffer.
- Pressing **[Alt]-F7** or **[Ctrl]-F7** (PANIC END) produces similar action to **[F7]** except that all pending transmit data is abandoned and a disconnect request is issued immediately. Use this key combination only if you need to get off-the-air very quickly! Use of **[Alt]-F7** or **[Ctrl]-F7** may force the other station to "retry out".

Initiating an ARQ CQ: To initiate an ARQ CQ call, press **[Alt]-F9**. The DXP38 will begin sending the CLOVER-II CQ sequence, a special version of the CCB ARQ format. The number of CQ calls is set with the "Fail Retries" parameter on page 1 of the configuration file (see Figure 4.8). Other CLOVER stations on your frequency will see a message at the top left of their screen "ARQ CQ from (your call)".

Answering an ARQ CQ: To answer an ARQ CQ call, press **[Ctrl]-F9**. Your station will respond by linking to the calling station and you will see the other station's call at the top of your screen. If a CQ CCB is received, your transceiver is already tuned close enough in frequency to link. Use the Frequency Error Bar to fine tune after the link is established.

If a CCB fails to decode during the connect process, it will cause both stations to return to standby mode, regardless of the retry counters. Once a connection is established the link will hold together very tenaciously.

Performance Hints For Keyboarders: If there are fewer than 256 characters pending, they will be sent using the "slow" CCB "Chat Mode". As soon as you exceed 255 pre-buffered transmit characters, CLOVER-II will "shift gears" and begin transmitting data in large data blocks using faster modulation forms. Block mode transmission will continue until all pending transmit text has been sent. When all available data has been sent, CLOVER will return to "Chat Mode". If you wish to immediately shift out of "Chat mode" to higher rate modes, preload the transmit buffer with at least 255 characters (about 3 1/2 lines) - a fully-loaded HERE IS message may be used for this purpose.

CLOVER-II is bi-directional. Both operators may type at the same time and data will be sent in both directions automatically without use of "OVER" commands. This feature works both in "Chat Mode" and in long-block ARQ data mode.

If echo enable is turned ON (Configuration Menu, page 1), your transmitted text will appear in the receive window as it is being encoded for transmission. Received text is shown as "**bright video**" and echoed transmit text as "dim video". In some case, it may be less confusing to turn echo OFF and only display received text in the RX buffer screen area.

4.10.4 FEC Mode

While ARQ is the prevailing means of communications within CLOVER-II for passing traffic and general conversation, occasionally there is a need for a "one-station-to-many" broadcast. The FEC mode serves to provide just such a service. Any station tuned to the frequency of the FEC transmission will be able to monitor it. Errors are corrected at the receiving station, although it is not possible to request repeats. Also, FEC is not adaptive so you must make some judgement about current band conditions and select the modulation for your FEC transmission. The modulation you select can be changed during transmission.

- Modulation modes: 2DPSM, BPSM, QPSM, 8PSM, 8P2A, 16P4A

In general, more robust modes for poor band conditions are the slower modulation rates (the first few in the above list).

ARQ features not available in FEC mode are:

- Repeat of blocks whose errors exceed the Reed-Solomon capacity
- Adaptive modulation control
- Chat, 1-way block or 2-way block modes

While all modulation modes may be used for FEC transmissions, it must be remembered that very good propagation conditions are required to support the high data rate modes. It is advisable to be "conservative" in the choice of transmission modes, particularly when FEC is used to send data to multiple stations. QPSM modulation generally works well under typical daytime conditions and provides throughput of 20 bytes per second (three times the AMTOR rate). If conditions are poor or disturbed, use BPSM. 8PSM mode should be reserved for situations in which the propagation path is known to be stable.

This table shows how to:

- Enter FEC mode
- Select the modulation and efficiency
- Initiate the FEC transmission
- End the FEC transmission

STEP	ACTION																
1	Press [F1] to access the CLOVER main menu.																
2	Press M to display the Mode sub-menu.																
3	Press F to select FEC. Information below should appear on your screen. <table border="1" data-bbox="553 520 1166 657" style="margin-left: auto; margin-right: auto;"> <thead> <tr> <th colspan="2" data-bbox="610 527 805 552">WAVEFORM</th> <th colspan="2" data-bbox="919 527 1068 552">DATA RATE</th> </tr> </thead> <tbody> <tr> <td data-bbox="610 558 753 583">Modulation</td> <td data-bbox="789 558 867 583">BPSM</td> <td data-bbox="919 558 1045 583">Base Rate</td> <td data-bbox="1068 558 1107 583">125</td> </tr> <tr> <td data-bbox="610 590 743 615">Code Effic</td> <td data-bbox="789 590 847 615">60%</td> <td data-bbox="919 590 1003 615">Actual</td> <td data-bbox="1068 590 1107 615">75</td> </tr> <tr> <td data-bbox="610 621 750 646">Block Size</td> <td data-bbox="789 621 831 646">85</td> <td></td> <td></td> </tr> </tbody> </table>	WAVEFORM		DATA RATE		Modulation	BPSM	Base Rate	125	Code Effic	60%	Actual	75	Block Size	85		
WAVEFORM		DATA RATE															
Modulation	BPSM	Base Rate	125														
Code Effic	60%	Actual	75														
Block Size	85																
4	Use the [space bar] to toggle through the selections, then press [Enter] to initiate the FEC transmission. Note: Remember to use [Alt]-F10 to toggle the TX EN/DIS to enable the transmit buffer.																
5	Press [F7] to end the FEC transmission. Result: CLOVER terminates the FEC transmission including your CW ID if it is enabled.																

4.10.5 Listen Mode

Listen mode is a passive monitoring mode, similar to the Listen mode in AMTOR. It allows you to monitor any CLOVER activity that may be occurring. To enter Listen mode, you press **[F1]** then **M** to access the Mode menu. Then press **L** to select Listen from the mode menu and use **[space bar]** to toggle Listen on. The same series of actions are used to toggle Listen off.

Another method of toggling Listen mode on or off is to press **[F8]**. As you do, LISTEN will replace STBY on the status line. Press **[F8]** again and you return to STBY (stand-by).

Listen mode is active when you are not linked. Links can still occur even if Listen mode is ON.

4.10.6 Test Mode

The DXP38 Test mode provides two different selections of test tones: Single Tone Test and Four Tone Test. As discussed in Chapter 2, Test mode is used to set the transmit audio level. Follow the procedures of section 2.3 any time you alter the set-up of your transceiver to verify that the audio output levels are correctly set.

4.10.7 CLOVER-II Configuration Menu Parameters

Page 1 of the Configuration menu includes three menu fields that are used to view and program CLOVER-II parameters. Most of these parameters may also be set via front screen menus and/or "hot-keys". However, general practice is to set-up the power-on default values in the Configuration menu and then save the configuration.

FEC Menu: The CLOVER-II FEC mode may be set in the front screen MODE-CLOVER-FEC menu or via page one of the Configuration menu. The parameters are:

Modulation:	2DPSM, BPSM, QPSM, 8PSM, 8P2A, 16P4A
Code Effic:	60% (Robust), 75% (Normal), 90% (Fast)
Block Size:	51, 85, or 255 bytes (coupled to modulation selection)

ADAPTIVE ARQ Menu: The following ARQ parameters are only set via the Configuration menu:

Auto Bias:	Robust (60% RS), Normal (75% RS), Fast (90% RS)
Connect Retry:	Number of connection retries before the link fails (00 – 99)
Fail Retry:	Number of block retry failures before link fails (00 – 99)
Chat Count:	CCB cycles before ARQ changes from CCB to long block mode (0-9)

LISTEN Menu: LISTEN mode may be either turned ON or OFF via the Configuration menu. The action is identical to use of the main screen CODE (CLOVER) and MODE (LISTEN) menu selections.

4.11 Operating AMTOR

AMTOR is an error-correcting communication mode, also known as "TOR", "SITOR" or CCIR-476 and CCIR-625. TOR actually has four sub-modes that may be chosen: (1) ARQ ("Mode A"), (2) FEC ("Mode B"), (3) LISTEN ("Mode L"), and (4) STBY (Standby).

AMTOR ARQ mode is sent in pulses and both stations transmit in a time-sequenced order. Each station automatically requests a repeat if an error is detected. In FEC (broadcast), each character is sent twice (with a time separation). LISTEN is a receive-only mode that may be used to listen to ARQ or FEC signals. LISTEN mode cannot correct errors in received ARQ mode signals. STBY mode is the normal "rest" condition of an AMTOR station when monitoring a frequency. When your SEL-CAL code is received, the modem automatically switches from STBY to ARQ mode and responds. FEC reception is also automatic from STBY mode.

4.11.1 ARQ Mode

AMTOR ARQ mode may also be called "Mode A". The letters "ARQ" stand for Automatic Repeat ReQuest (or Query). ARQ is an error-detection mode in which one station sends a group of three characters and the other station may either acknowledge correct reception or request a repeat transmission. This is similar to CLOVER-II ARQ mode except that AMTOR cannot correct errors without repeat transmission and the AMTOR code itself is not completely "infallable" – AMTOR can print errors. The transmitters of both AMTOR ARQ stations are pulsed ON and OFF every 450 ms. ARQ mode requires use of transmitters and receivers that can rapidly switch between receive and transmit. Use of HF radio equipment that has TX/RX switching times less than 20 ms is highly recommended. An ARQ link may be started by using either the main screen COMMAND menus or by typing "hot keys".

Start ARQ via the COMMAND menu:

STEP ACTION	
1	Press [F1] . COMMAND menu will appear with CODE Highlighted.
2	Press [ENTER] . The CODE menu will be shown.
3	Use the [up-arrow] or [down-arrow] keys to highlight AMTOR .
4	Press [ENTER] . The ARQ menu now appears.
5	Type a new SEL-CAL code or choose one of the CALL DIRECTORY choices.

Start ARQ via "HOT KEY":

The **[F9]** "hot key" bypasses steps 1 through 5 above and immediately shows you the SEL-CAL menu. **[F9]** is by far the easiest way to get on-the-air in ARQ mode. The sequence is:

STEP	ACTION
1	Press [F9] .
2	Set SEL-CAL code and press [ENTER] .
3	Your station starts sending the other station's SEL-CAL code.
4	The other station recognizes his SEL-CAL and responds.
5	Enable your transmit buffer by pressing [F10] . (You will see "EN" on the status line.)

The ARQ Link: Once these steps have been successfully completed, the two ARQ stations will be synchronized and you may send text to the other station. However, no text will be passed until the first five steps have been completed. When a link is in progress (not all five steps complete), the top line of the screen will display the message:

CALLING- (KKCW) ----- AMTOR -----

The center status line will show:

AMTOR ARQ PHS ISS NORM EN WORD

This indicates that an ARQ call is in progress, you are the ISS (Information Sending Station), and that the call-up sequence is in progress. Your transmitter should now be pulsing ON and OFF ("chirping").

Once the link has been established, the "Calling" label will change to "Linked With XXXX". If your receiver speaker is turned ON, you will also hear the other station's short "chirp" response (control signals).

If you do not get a response from the other station, the TIME OUT option controls whether your transmitter continues "chirping forever" (TO = OFF) or the ARQ call automatically "times-out" (TO = 32 or 128). The TIME OUT (TO) option is normally set to "32" but may be changed on page 3 of the CONFIGURATION menu. A "quick-kill" or "panic-stop" may be done at any time by typing **[Ctrl]-F7** keys.

The DXP38.EXE transmit text buffer may be used pre-type your transmit text. Transmitted characters are "echoed" on the receive screen as they are sent ("Echo As Sent"). You can always gauge the progress of the ARQ transmitted output by looking at the receive buffer. If your typing is not as fast as the transmitted rate, AMTOR "idle" characters are automatically inserted (indicated by "IDL" instead of "TFC" on the center status line).

If the ARQ link detects errors, The "TFC"/"IDL" status line indicator will change to "ERR" to show that an error has been received or "RQ" if the other station has requested a repeat. The "ERR" and "RQ" labels will usually flash very quickly and may not be noticeable on good quality links. However, if either "ERR" or "RQ" are frequently observed, it may be a sign that conditions are not good and the ARQ link might fail.

ARQ OVER Commands: If you are the current ISS (Information Sending Station), all you need to do to let the other station talk is end your typed comments with the plus(+) and question mark(?) characters (+?). These characters are entered into the transmit buffer and a special ARQ control sequence is executed when +? is sent. The +? "OVER" sequence reverses the roles of the two stations. If you type +?, your station becomes the IRS (Information Receiving Station) and the other station becomes the ISS. He may then send text to your station. Likewise, he can return sending control to you by typing +?. Unlike CLOVER, the AMTOR ARQ link passes information only direction at a time. A +? OVER sequence must be sent to change the direction of data flow. You may enter the OVER command by either pressing the **[F6]** key or by typing +?. This "OVER" command works ONLY at the ISS.

Use **[Ctrl]-F6** to inject a FORCED OVER operation. If you are the IRS, the FORCED OVER is the only way your station can reverse the channel. A FORCED OVER command operates immediately and therefore interrupts whatever the other station is sending. Use it with care!

Even when a FORCED OVER is used, DXP38.EXE preserves any unsent text in the transmit buffer. This text will be held and sent ahead of any additional pretyped text when your station is

again the ISS. You may, however, erase the entire transmit buffer at any time by pressing **[Alt]-V**. Be careful - you could lose a lot of pre-typing!

"OVER" options:

1. If ISS, press **[F6]** or **+?** at end of your text to be sent
2. If IRS, press **[Ctrl]-F6** to immediately reverse the channel.

END Commands: AMTOR ARQ mode requires that an "END" command be sent at the end of the Link. If you are the ISS, END an AMTOR Link by typing either the **[F7]** key or **ZZZZ** into the transmit buffer. (Actually, **[F7]** also enters "ZZZZ" into the transmit buffer but its use saves 3 key strokes). When "ZZZZ" is sent, it automatically triggers the required TOR END control sequence.

As in the case of OVER, there is also a "FORCED END" command that may be used to immediately stop the link. Typing **[Ctrl]-F7** produces a FORCED END operation when operating as either ISS or IRS. However, a FORCED END operates immediately and does not wait until all text has been cleared out of the TX buffer. **[Ctrl]-F7** is also known as "panic-kill" for ARQ mode.

ARQ WRU Feature: The AMTOR WRU (Who aRe yoU) feature allows the other station to confirm the identity of your station. Some Email programs use WRU when the first connection is made to the mailbox system. A special character is sent by the mailbox station that causes the DXP38 to respond with the ANSWERBACK message (a special type of "HERE IS" message).

The WRU feature may be turned ON or OFF, using the CONFIGURATION and TOR menus. The ANSWERBACK message is stored in HERE IS 9 (CONFIGURATION, Page 2).

Assuming that WRU is turned ON and an ANSWERBACK message is programmed, the full operation sequence for WRU is as follows:

1. Station one is ARQ ISS and sends "\$" (dollar sign; FIGS-D)
2. The DXP38 at station two forces an OVER to become the ISS
3. Station two sends the ANSWERBACK text (HERE IS 9)
4. Station two sends a normal OVER, restoring the original ISS/IRS configuration

ARQ Mode Parameters: Several operating parameters for ARQ mode may be set via "Page 3" of the CONFIGURATION Menu. These parameters have the following meaning

WRU:	Enable or disable WRU mode.	Default = OFF
TIME OUT:	Turn time-out ON or OFF. When ON, an ARQ call to another station will cease after 1 minute of unsuccessful calls.	Default = ON
TD:	Transmitter turn on delay; the delay from setting the Push-To-Talk (PTT) line to transmit (TX) state and the start of the AFSK tones. Data modulation of the tones starts 5 ms after PTT is set to TX	Adj: 5-99 ms Default = 10 ms
CD:	Control delay between the end of a received block and the start of the first IRS transmission.	Adj: 10 - 99 ms. Default = 50ms.
MY 476 SCAL:	Selective call (SEL-CAL) characters for my station in CCIR-476 format.	
MY 625 SCAL:	Selective call (SEL-CAL) characters for my station in CCIR-625 format.	

4.11.2 FEC Mode

AMTOR FEC mode is also called "Mode B" and/or "Collective Broadcast Mode". FEC uses the same 7-bit character code as ARQ mode but sends each character twice, separated by the time it takes to send four other characters (called a "4-character interleave"). If the first received character is in error, the FEC mode receiving equipment examines the second character.

Starting FEC Mode: To start FEC mode, access the COMMAND menu and select FEC. FEC mode does not require a SEL-CAL code and may be used much like RTTY.

FEC Return to STBY Mode: In some cases, it is desirable for the DXP38 to return to AMTOR-STBY mode rather than to FEC-only receive mode. In this case, insert ZZZZ at the end of the transmitted text. The **[F7]** key may be used to insert the ZZZZ sequence.

FEC may also use the "panic kill" hot-key -- **[Ctrl]-F7**. In this case, pressing **[Ctrl]-[F7]** causes an immediate end to an FEC transmission and returns the DXP38 to AMTOR STBY mode (not to FEC). Use **[Ctrl]-F7** with restraint!

4.11.3 LISTEN Mode

The DXP38 includes a receive-only mode to monitor all AMTOR signals. The LISTEN mode (also called "MONITOR") automatically selects the AMTOR mode and decodes characters from ARQ or FEC received signals. To start LISTEN mode, access the COMMAND menu and select LISTEN. When in AMTOR Listen, the DXP38 will also respond to P-Mode link requests.

4.12 Operating P-Mode

P-Mode is the HAL designation for a communications protocol that may also be known as "Pactor", a registered trademark of the Spezielle Communications System GmbH (SCS) firm in Hanau, Germany. P-Mode has four sub-modes that may be chosen: (1) ARQ, (2) FEC (UNPROTO), (3) LISTEN, and (4) STBY (Standby).

4.12.1 ARQ Mode

Start ARQ via the COMMAND menu:

1. Press **[F1]**. The first COMMAND menu will appear with CODE highlighted.
2. Press **[ENTER]**. The CODE menu will be shown.
3. Use **[up-arrow]** or **[down arrow]** keys to highlight P-Mode.
4. Press **[ENTER]**. This establishes P-Mode STBY condition.
5. Press **[F9]**. This initiates the ARQ link.
6. Type the other stations call sign and **[ENTER]**.
7. The P-Mode ARQ calling sequence will begin.

Start ARQ via "HOT KEY":

The **[F9]** "hot key" bypasses steps 1 through 5 and immediately shows you the call sign menu. **[F9]** is by far the easiest way to get on-the-air in ARQ mode.

P-Mode Call Signs: Unlike AMTOR, but like CLOVER, P-Mode does not require a special selective call sequence of letters. Rather, the call sign of each station is used directly. Therefore, no special steps need be taken to program a "SEL-CALL" sequence for P-Mode.

The ARQ Link: The sequence at the beginning of an ARQ QSO is as follows:

STEP	ACTION
1	Press [F9] .
2	Select the call sign and press [ENTER] .
3	Your station starts sending the other station's call sign.
4	The other station recognizes his call sign and responds.
5	Enable your transmit buffer by typing [F10] .
6	Start typing transmit text.

Once the link has been established, the "Calling" label will change to "Linked With XXXX". If you do not get a response from the other station, the MAX ERROR option controls whether your transmitter continues "chirping forever" (MAX ERROR = 255) or the ARQ call automatically "times-out" (MAX ERROR = 30, the minimum). The MAX ERROR option is normally set to "80", but may be changed in the CONFIGURATION menu. You may do a "quick-kill" or "panic-kill" at any time by typing the **[Ctrl]-F7** keys.

ARQ OVER Commands: In ARQ mode, information flow is one-way, even though both transmitters are alternately "chirping away". Like AMTOR, P-Mode ARQ requires use of the OVER command to change the direction of data flow. There are two slightly different versions, "Normal OVER" and "Forced OVER".

If you are the current ISS (Information Sending Station), end your transmission with the plus and question-mark characters (+?). A special ARQ control sequence is executed when +? is sent, reversing the roles of the two stations. The original ISS (Information Sending Station) becomes the IRS (Information Receiving Station) and the other station becomes the ISS. OVER commands can be entered either by typing **[F6]** or typing +?. The "OVER" commands works ONLY for the ISS.

Use **[Ctrl]-F6** to inject a FORCED OVER operation. If you are the IRS, the FORCED OVER is the only way you can reverse the channel without waiting for the other station to finish his typing. Keep in mind that a FORCED OVER operates immediately and therefore interrupts whatever the other station is sending. Use it with care!

Even if a FORCED OVER is used, the DXP38 preserves unsent text in the transmit buffer. It will be held until the station becomes ISS and then sent ahead of any newly entered text. You may, however, erase the entire transmit buffer at any time by typing **[Alt]-V**. Be careful - you can lose a lot of pre-typing!

"OVER" options:

1. If ISS, type **[F6]** or **+?** at end of your text to be sent
2. If IRS, type **[Ctrl]-F6** to immediately reverse the channel.

END Commands: P-Mode requires that an "END" command be sent at the conclusion of an ARQ link. At the ISS, stop the link by typing **[F7]** or **ZZZZ** into the transmit buffer. **[F7]** actually enters "ZZZZ" in the transmit buffer as well, but saves 3 key presses. "ZZZZ" automatically triggers the required END control sequence. Only the ISS can issue the END command.

As in the case of OVER, a "FORCED END" or "Panic Kill" command may be used to immediately stop the link. Type **[Ctrl]-F7** to give a FORCED END when operating as either ISS or IRS. Note that a FORCED END operates immediately and does not wait until any pre-typed text has been sent. Any unsent text will be cleared from the transmit buffer when **[Ctrl]-F7** is typed.

ARQ P-Mode Parameters: Several operating parameters for ARQ mode may be set via Page 3 of the CONFIGURATION Menu. ARQ mode parameters have the following meaning:

CS DELAY:	Delay between the end of a received block and the start of the first IRS control data bit.	Adj: 10-50 ms Default=30 ms.
MAX DOWN:	In ARQ mode, the maximum number of flawed data blocks before reducing the data rate from 200 baud to 100 baud.	Adj: 2-30 Default=6
MAX UP:	In ARQ mode, the number of error-free blocks before increasing the data rate from 100 baud to 200 baud.	Adj: 2-30 Default=3
MAX TRY:	In ARQ mode, the maximum number of attempts to increase the data rate from 100 to 200 baud.	Adj: 0- 9 Default=2.
MAX ERROR:	In ARQ mode, the maximum number of retries when calling to link or maximum repeats to correct errors during a link.	Adj: 30-255 Default=80
MAX ARQ SUM:	In ARQ mode, the maximum number of the memory-ARQ counter. Memory-ARQ summation is cleared when MAX ARQ SUM is exceeded.	Adj: 5-60 Default=10
HUFFMAN:	In ARQ and UNPROTO/FEC modes, enable or disable Huffman data compression coding.	Default=ON.

4.12.2 FEC Mode (UNPROTO)

P-Mode UNPROTO (FEC) uses Forward Error Correction. FEC uses the same character code as P-Mode ARQ but sends each character 2 to 5 times, separated in time. If the first received character is in error, the FEC receiving equipment examines the 2nd, 3rd, etc. character.

FEC Data Rates: P-Mode FEC (UNPROTO) transmissions may use either a data rate of 100 or 200 baud. The rate is selected at the beginning of a transmission. Unless the communications path is extremely stable, 100 baud is recommended.

Starting FEC Mode: To start FEC mode, access the COMMAND menu and select FEC. FEC does not require a call sign code.

FEC Send/Receive Control: The FEC code actually sends P-Mode frames without an ACK/NAK response. There is no special startup as with AMTOR. Once FEC mode is started you must use **[F7]** to return to receive except as stated below.

FEC Return to STBY Mode: In some cases, it is desirable for the DXP38 to return to P-Mode STBY rather than to FEC-only receive. In this case, insert **ZZZZ** at the end of the transmitted text. The **[F7]** key may be used to insert the ZZZZ sequence.

FEC also includes a "panic kill" hot-key -- **[Ctrl]-F7**. Pressing **[Ctrl]-F7** causes an immediate end of the FEC transmission, clears any unsent text out of the transmit buffer, and returns the DXP38 to STBY mode (not to FEC). Use **[Ctrl]-F7** with restraint!

FEC Configuration Parameters: Two parameters apply to FEC mode:

FEC REPEATS:	The number of times each character to be transmitted is repeated.	Adj: 2-5 Default=2
HUFFMAN:	In ARQ and UNPROTO/FEC modes, enable or disable Huffman data compression coding.	Default=ON.

4.12.3 LISTEN Mode

The DXP38 includes a receive-only mode used to monitor P-Mode transmissions. The LISTEN mode (also called "MONITOR") will automatically select the mode and decode characters from ARQ or FEC (UNPROTO) received signals. In LISTEN mode, the DXP38 responds only to P-Mode link requests. However, the DXP38 will also respond to AMTOR link requests when in P-Mode STBY mode.

Chapter 5

In Case Of Difficulty

This chapter provides general guidance in case your DXP38 hardware or software no longer function correctly. Please read all sections before attempting maintenance or returning your modem to the factory.

5.1 User Adjustments and Alignment

The DXP38 circuitry is completely digital and has *no* alignment controls. However, there are user-settable jumpers and an output level control that might be incorrectly set. The correct procedures to set these options are discussed in the manual sections shown in Table 5.1 below. Before considering any other maintenance procedures, re-read the referenced section and confirm that each option is set correctly.

Table 5.1
User-Set Options

SETTING	FUNCTION	MANUAL SECTION
J3	Modular Output Range	Section 2.2.2; Table 2.2
R1	Modular Output Level	Section 2.2.2; Table 2.2
J6	FSK Level	

Unless changes have been made in the PC or radio system, none of these options should have changed from when the DXP38 was first installed.

5.2 DXP38 Hardware Problems

DXP38 hardware problems will generally be caused by one or more of the following situations:

1. Incorrect DC power connector: The DXP38 uses a coaxial DC power plug. The correct plug is HAL P/N 310-16030. Additional plugs may be purchased directly from HAL. The correct dimensions of the plug barrel are: 2.5 mm ID x 5.5 mm OD x 9.5 mm long. Use **ONLY** the correct plug! Many "all-purpose" plugs look similar but do not provide reliable connection.
2. Inadequate PC power supply capacity: The DXP38 requires a stable +12VDC power supply. While a 250 ma power supply will support normal operation of the DXP38, a supply with a capacity of 500 ma is required when programming the Flash ROM.
3. Incorrect voltage or excessive current: Exceeding the voltage or current rating of any of the radio I/O connections may damage DXP38 components. The maximum rating of each connection is shown in Table 2.1; do not exceed these limits. Static electricity or lightning is a common way that one or more of these limits may be exceeded.
4. Radio problems: Faults in the transmitter or receiver may at first appear to be DXP38 problems. Confirm that radio controls are set correctly and that the radio equipment operates as it should.

5. Transmitter RFI into PC or modem: Radio frequency interference can be a major problem, particularly if transmitter energy invades the PC itself. A good RF ground connection (1/4" wide shield braid) should always be made between the cabinets of the PC and the radio equipment. All cables should be shielded and as short as possible - no more than ten feet long. Test for transmitter RFI by transmitting at very low power into a well shielded dummy load (1 to 10 Watts). If the DXP38 works correctly with low power into a dummy load but not with normal power to the antenna, the RFI problem *must* be cured before the DXP38 may be used to its full potential.

6. RFI into the receiver: RFI to the receiver may be heard in the form of "birdie" signals at various frequencies. As in the case of transmitter RFI, good grounding, shielding, and short cables are the best cures. Also, "modern" PC cabinets and CRT monitors (made since 1991) have *considerably* better shielding and RFI suppression than their predecessors. Pre-1991 slow PC's (PC-XT, etc.) tended to generate less RFI than faster models ('286, etc.). Since 1991, this no longer appears to be the case as modern '386 PC's are often quieter than early PC-XT's.

5.3 Software Problems

The relative ease by which DXP38 software may be upgraded or changed can cause unanticipated problems. This is particularly true when new upgrade files are uploaded into the flash memory of the DXP38. Whenever new files from HAL are loaded and used, be sure to use all of the new files provided and do not mix old and new versions of the files. This is particularly true of mixing different releases of DXP38.S28 (68000 software) and DXP38.LOD files (DSP software). Also, when upgrading software, be sure to delete all previous versions of DXP38.CFG you may have previously created. You may obtain current software via Internet (www.halcomm.com) or by contacting customer service (see 5.5 User Service). Downloaded files are in compressed (.zip) format. HAL recommends that you download the file to a floppy disk, unzip the file to the floppy, and store it as a backup. Refer to Chapter 4 Loading DXP38.EXE and to section 4.7.6 to upload current DXP38.S28 and DXP38.LOD files.

5.4 Operational Problems

CLOVER-II is a relatively new waveform and new protocol. Some operations that are in fact "normal" may at first appear to be a "problem". Typical situations that may produce confusing results are:

1. CLOVER-II signals must be tuned correctly at the *receiver*. Optimum performance will be obtained only when tuning is correct. However, the CLOVER modem must also obtain frequency, phase, and time synchronization from the received signal. To minimize the effects of noise and short-term ionosphere variations, a running-average integration is computed over a 2 second period (approximate length of a data pulse). Each time the receiver tuning control is adjusted, the integration process is disturbed and that data block will usually be "damaged" - data will not be recovered and a repeat will be necessary in ARQ mode. Further, it may take receipt of several more data blocks to regain synchronization. CLOVER-II transmissions also use long blocks, up to 20 seconds long. The tuning indicators are updated only *once per data block*. Receiver tuning adjustments at a faster rate will not produce useful results and may in fact confuse the system. The following guidelines are recommended:

- a. Tune the receiver *slowly*. One increment per data block is sufficient.
- b. Avoid the temptation to make small frequent receiver adjustments.

2. CLOVER-II adaptive ARQ mode measures receive signal parameters and then sets the optimum transmit modulation mode *from the other station*. If your station appears to not be able to send data at a fast rate, it is due to receive conditions *at the other station* and usually *not* transmit problems at your station.
3. If it appears that many stations have difficulty transmitting data to you at a high rate, it *could* be due to a problem in your receiving equipment, particularly if these also appear to be strong and stable signals. Typical receiver parameters which can limit CLOVER performance are:
 - a. Receiver AGC set to FAST mode will distort 8P2A or 16P4A - use SLOW AGC or the manual RF gain control.
 - b. Always use the standard SSB receiver filter.
 - c. A noise limiter or blanker distorts CLOVER - turn it OFF.
 - d. Receiver drift can exceed CLOVER compensation - retune as required.
4. CLOVER-II uses long data blocks and multi-level modulation to obtain high data throughput. However, the ARQ transmit/receive protocol operates much slower than other popular ARQ modes - AMTOR, P-Mode, or packet radio. It must be remembered that all aspects of CLOVER ARQ mode occur at a slow rate and that major changes must occur in increments of 19.5 seconds (ARQ frame time). Have patience and wait for CLOVER to finish its assigned task before rushing into a new mode or assuming that something is not quite right.

5.5 User Service

The DXP38 does not require periodic alignment or renewal of any component. Components should be replaced only if they fail and not as a part of any routine maintenance procedure. As a general rule, component replacement should be done at the factory under controlled ESD (Electro-Static Discharge) conditions. Before returning the DXP38 to the factory, please check the following:

1. The DC power plug is making reliable contact.
2. Cables to the DXP38 are installed and are not open or shorted.
3. All jumpers and option switches are set correctly.
4. All other features of your computer and radio equipment function correctly.

If the above items are correct, contact the factory to arrange for return and repair.

5.6 User Information

User information and support for the DXP38 is available via telephone, FAX, or our Internet web page (www.halcomm.com). You may also use the web page to obtain current DXP38 software releases and user service bulletins.

Before contacting customer service, have the model number, serial number, software version numbers, and name or original ordering customer available.

Customer service may be contacted via:

Mail: HAL Communications Corp.
Customer Service Department
1201 W. Kenyon Road
Urbana, Illinois 61801

Phone: (217) 367-7373, 8 AM - 5 PM CST/CDT, Monday - Friday
FAX: (217) 367-1701, 24 hours/day
INTERNET: Web Page: www.halcomm.com
E-mail: halcomm@halcomm.com

5.7 Returning Equipment for Factory Repair

If your equipment must be returned to HAL for repair, please do the following:

1. Call, FAX, or write to HAL and obtain a *Return Authorization*.
2. *ALWAYS* include the following information *in the package containing the item to be repaired*:
 - a. Your name, address, and phone number for return of the repaired equipment. *Give a street address if at all possible.*
 - b. Model, serial number, and approximate purchase date of returned item.
 - c. If the warranty period has expired, the payment means you prefer. See Chapter 6 for warranty details.
 - d. A *short but informative* description of the problems. "Broke" is too short; 2 or more pages is usually too much!
 - e. The shipping carrier or means by which the equipment should be returned to you. HAL will use UPS (Brown Label) shipping unless otherwise directed.
3. Carefully pack the DXP38 and protect it from shipping damage. The original HAL carton is a good choice if it is available and undamaged. A new carton may be purchased from HAL.
4. Insure the DXP38 for its full value.
5. Clearly mark HAL's name, address, and "ATTN: SERVICE" on the shipping box.

The HAL service department attempts to repair all equipment within 30 days of its arrival at HAL. If the repairs cannot be made within 30 days, you will be notified by mail of the approximate shipping date. You may call the HAL service department to confirm repair dates.

If you require rush service of your DXP38 please notify HAL and we will make all attempts possible to expedite your repair. However, our service time is often conditional upon arrival of parts which is not within our control. Also, please understand that testing takes time and that each hardware repair should be "burned-in" for an extended period (24 hours) and re-tested.

Also, be sure that you have thoroughly checked all other equipment connected to the DXP38 and that the modem is actually at fault. It takes much longer to test a device that is in fact not defective. We must charge for all repair time, including time spent testing a device that is not defective. A thorough examination of the problem by you and a clearly written description of problems noted will save time and money for both of us.

Chapter 6

DXP38 Specifications

INPUT/OUTPUT:

AF IN:	Audio input signal from receiver 30 mV to 1.7 V rms (-30 to +7 dBm) Zin = 10,000 ohms
AF OUT:	Audio output signal to transmitter 2.5 mV to 0.25 V rms (-50 to -10 dBm) Zout = 600 ohms
PTT:	Push-To-Talk TX/RX control output +50 VDC open-circuit (RX) maximum +100 mA DC closed-circuit (TX) maximum
FSK:	FSK transmit data output +50 VDC open circuit maximum +100 mA DC closed circuit maximum
SEL-CAL:	Selective Call control output +50 VDC open circuit maximum +100 mA DC closed circuit maximum

CLOVER-II WAVEFORM:

Tone Pulses: 4 Tone pulses, spaced 125 Hz and 8 ms apart; amplitude shaped for -60 dB composite side-lobe suppression.

Tone	Chan 1	Chan 2	Chan 3	Chan 4
Fc	750.0 Hz	1250.0 Hz	1750.0 Hz	2250.0 Hz
1	562.5 Hz	1062.5 Hz	1562.5 Hz	2062.5 Hz
2	687.5 Hz	1187.5 Hz	1687.5 Hz	2187.5 Hz
3	812.5 Hz	1312.5 Hz	1812.5 Hz	2312.5 Hz
4	937.5 Hz	1437.5 Hz	1937.5 Hz	2437.5 Hz

Frequency Spectra:	Fc \pm 250 Hz
Spectra:	Bandwidth = 500 Hz @ -50 below peak level.
TX Crest Factor:	Peak/Average \leq 2:1 (voltage) \leq 6 dB (power)
CCIR Emission:	500H J2 DEN or 500H J2 BEN
Symbol Rate:	31.25 baud, all modulation formats

Modulation Format: Six modulation modes using Phase Shift Modulation (PSM), Amplitude Shift Modulation (ASM), Frequency Shift Modulation, and multiple combinations.

MODE	DESCRIPTION	RATE
16P4A	16PSM+ 4 ASM	750 bps
8P2A	8PSM +2 ASM	500 bps
8PSM	8-ary PSM	375 bps
QPSM	Quadrature PSM	250 bps
BPSM	Binary Phase Shift Modulation	125 bps

Error Correction: Reed-Solomon (GF(2e8)) data encoding.
 Block Sizes = 17, 51, 85, 255 bytes
 Coding Efficiency = 60%, 75%, 90%

CLOVER-II PROTOCOL:

CLOVER Control Block (CCB) Underlying synchronizing and control signaling layer for all CLOVER transmissions.

CCB Format: Always same or more robust than data blocks.
 BPSM/17/60 for all ARQ transmissions

ARQ Mode: One transmitter to one receiver point-to-point mode.
 Reed-Solomon forward error correction coding
 Repeat transmission of uncorrectable data blocks
 Adaptive selection of waveform modulation for 5 ranges.

FSK MODES:

MODES: Baudot RTTY, ASCII RTTY, AMTOR, P-Mode
 FSK TONES: 500 Hz through 3000 Hz, programmable

FSK RTTY: Codes: U.S. Baudot / CCITT#2, ASCII
 Data Rates Baudot: 45, 50, 57, 75 Baud
 ASCII: 75, 110 Baud

AMTOR: Specification CCIR-476 & CCIR-625
 Modes ARQ, FEC, SEL-FEC, Listen
 Data Rate 100 Baud

P-Mode Modes Auto-ARQ, FEC, Listen
 Data Rates 100 / 200 Baud

PC TERMINAL SOFTWARE:

GENERAL: Both windows (DXPWin) and DOS (DXP38.EXE) terminal software included. Both feature split-screen RX/TX buffers, pull-down menu windows, "hot keys", programmable messages, HISCALL directory, Configuration menus and files,

Save to disk, Send from disk, Transmit editor, macro command key programming and storage, on-screen tuning indicators, on-screen real-time ionospheric channel statistics.

MENUS:	COMMAND Menu, CODE, MODE, CONTROL, MESSAGES, FILES, and CONFIGURATION sub-menus.
STORAGE:	250 Line Receive Buffer; 250 Line Transmit Buffer Save To Disk File Local ID and call sign (MYCALL) Call sign of last-worked station (LAST HISCALL) Call signs of ten frequently worked stations (HISCALLs) Ten HERE IS messages, each 255 characters long. CONFIGURATION files to save operating parameters
PRINTER:	ON/OFF control of LPT1 PC printer device.

HARDWARE:

AUDIO I/O	TI TLC-320AC01/2 14 Bit A/D & D/A Converter
DSP PROCESSOR	16-bit TMS320C25
CONTROL	16-bit 68EC000 Control Processor
MEMORY	Flash RAM loaded via serial I/O port
DATA PORT	Serial RS-232 Control/Data Port; @ 9600 bps (DE9)
POWER	+10 to +18 VDC @ 250 ma power (500 ma to program ROM)
INDICATORS	STBY, CALL, LINK, ERR, TX, RX, Tuning
RADIO I/O	RX Audio, TX Audio, PTT, FSK, SEL-CAL (Phono)

MECHANICAL:

CABINET	Black, Aluminum 7.5"W x 3.5"H x 10.75"D (19.1 x 8.9 x 27.3 cm)
CONNECTORS	Radio: Phono Connectors (5) Data: DE9S Connector Power: 5.5/2.5 mm Coaxial Power Connector (HAL P/N 310-16030)
WEIGHT	2.5 lbs (1.15 kg) net 5.0 lbs (2.3 kg) shipping

Limited Warranty

HAL Communications Corp. of Urbana, Illinois, hereby warrants to the purchaser that the product herein described shall be free from defects in materials and workmanship, and from failure of operation from ordinary use, for a period of one year from the date of sale to the purchaser.

In the event of a defect in materials or workmanship during the warranty period, HAL Communications Corp. will, at its own expense, repair the defective unit and replace any defective parts. The purchaser shall pay cost of shipping the unit to HAL Communications Corp. as well as costs of removal and reinstallation of the unit. HAL Communications Corp. will pay the shipping costs incurred in returning the unit to the purchaser. To obtain warranty service, the customer should:

1. Notify, as soon as possible, the Customer Service Department of HAL Communications Corp., Box 365, Urbana, Illinois, 61803, of the existence of a possible defect.
2. At the time of notification, identify the serial number, and the possible defect.
3. HAL Communications will issue a Return Authorization Number at this time.
4. Return the unit, freight prepaid. Include in the shipping carton a reference to the Return Authorization Number and a brief description of the problem.

Correct installation, use, maintenance, and repair are essential for proper performance of this product. The purchaser should carefully read the equipment manual. The purchaser will be billed for labor and shipping charges on any unit determined by HAL to be in working order when received for repair.

This warranty does not apply to any defect that HAL Communications Corp. determines is due to any of the following:

1. Improper maintenance or repair, including the installation of parts or accessories that do not conform to the quality and specifications of the original parts;
2. Misuse, abuse, neglect, improper installation, or improper operation, including improper AC power and RF grounding techniques.
3. Accidental or intentional damage.

All implied warranties are limited in duration to a period of one year from the date of purchase by the original retail purchaser. HAL Communications Corp. disclaims any liability for incidental or consequential damages arising out of the use of, or inability to use, this product. This warranty gives you specific legal rights, but there may be additional rights.

